

VSI

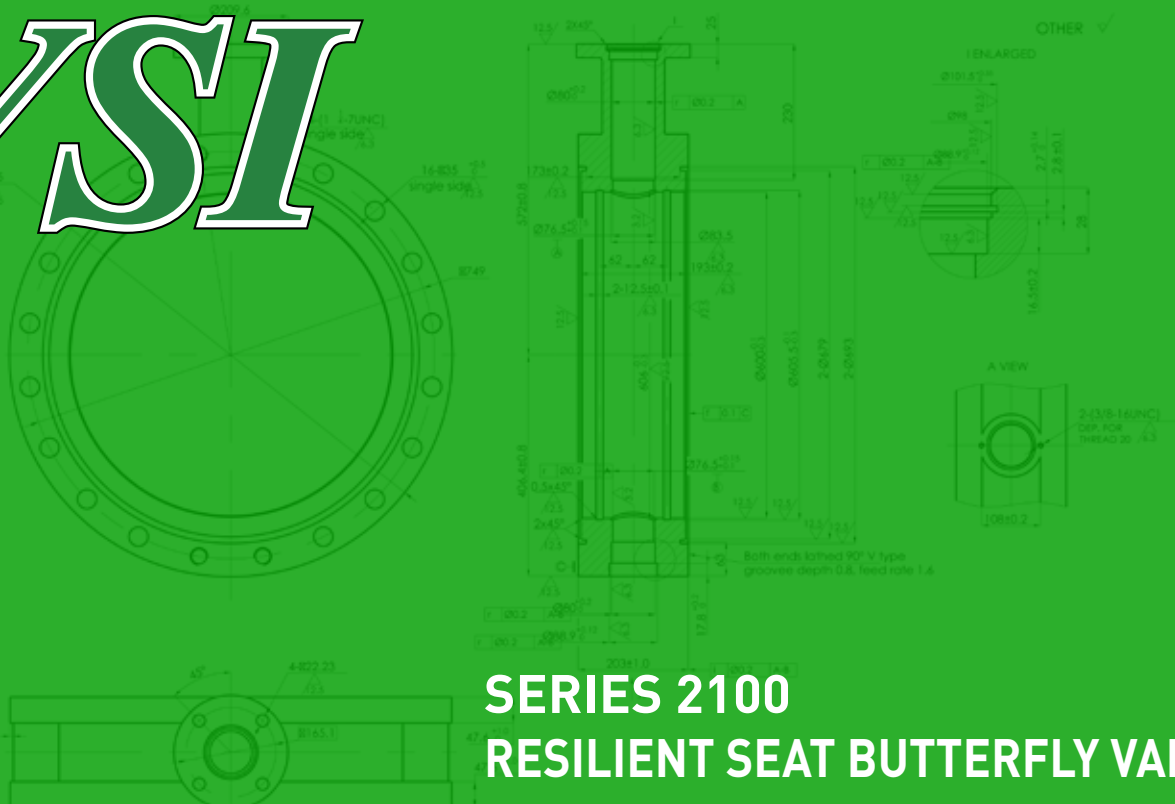

SERIES 2100 RESILIENT SEAT BUTTERFLY VALVES 2"-48"





IMPLEMENTATIONS

The Series 2100 has been thoughtfully designed and optioned to cover most common butterfly valve applications. The Series 2100 has been successfully specified and installed in commercial heating and air conditioning applications including chilled water, makeup water, and other water applications. Industrial applications such as sea water, food and beverage, paper and pulp, and even municipal water or air lines can easily be handled by the Series 2100 resilient seat butterfly valve.

AN VALVE FOR EVERY APPLICATION

VSI offers the Series 2100 Butterfly valve with thousands of operators and actuator options that make it the go to solution. The availability of different pressure class ratings as well as materials make it a versatile solution.

Every application is different, and VSI or your authorized reseller are here to help you with an valve and actuator assembly to fit your needs. The Series 2100 is available with simple options such as lever or gear operators all the way to complex solar powered or spring return electric units. Additionally VSI offers the Series 2100 in a 3-way butterfly valve assembly, an economical and efficient alternative to expensive hard to operate ball valves. We can help you find your Valve Solution.



TOP FLANGE

Conforms to ISO 5211 for the mounting of a wide range of actuators, levers, and gear operators

BUSHINGS

Five separate bushings provide correct alignment of the shaft through the body and reduces operating torque

BI-DIRECTIONAL DESIGN

The symmetric valve body and seat are of a b-directional design with no change in characteristics.

RESILIENT SEAT SURFACE

The resilient seat surface extends past the valve face to eliminate the need for gaskets on flanged installations. Installation time is greatly reduced by this feature

DEAD END SERVICE (OPTIONAL)

An option is available for the Series 2100 for dead end service when specified. With this option the valve is rated at its full differential pressure with no flange or pipe downstream.

BLOWOUT PROOF

The Series 2100 stem is fully retained by pins to the valve disc to form a blowout proof valve design.

MULTIPLE STEM SEALS

The stem is sealed by two separate o-rings and an integral seal in the seat to ensure absolutely no external leakage for the life of the valve.

LOW TORQUE DESIGN

The Series 2100 butterfly valve is available with a 100psi close-off rated disc that is undercut to reduce torque. The reduced torque allows the use of smaller, wider variety, and more economical actuators while still covering the close-off requirements of most HVAC applications.

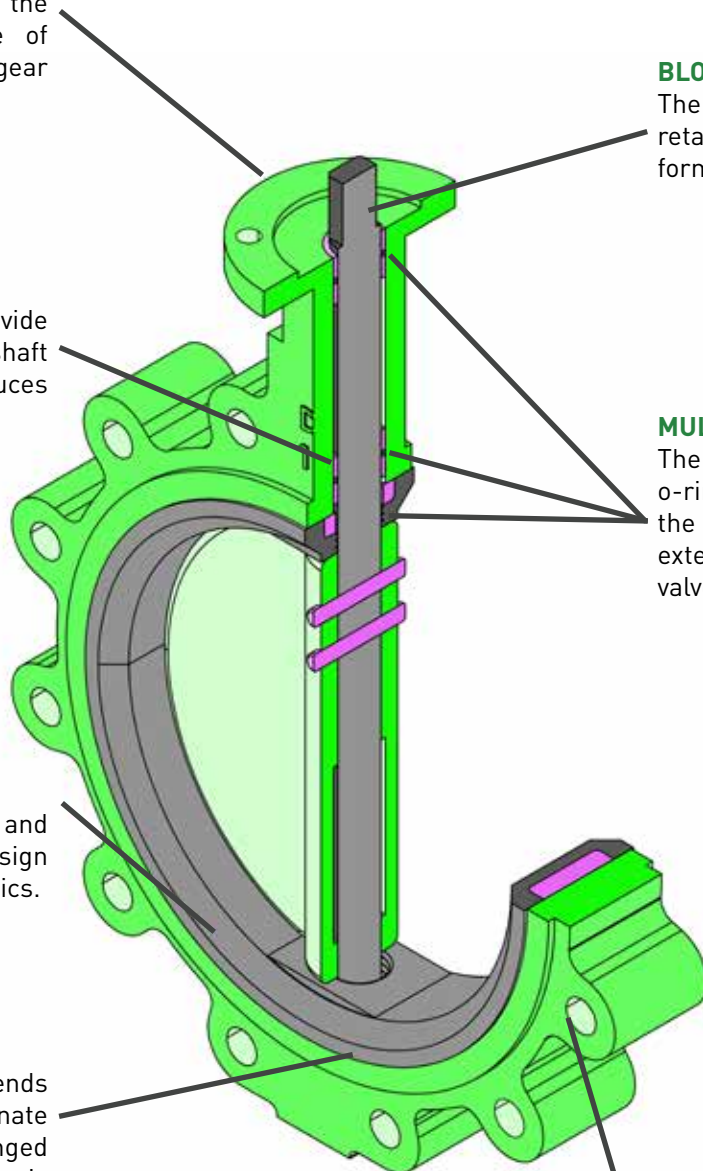



DESIGN STANDARDS

Size Range	2"-36" Lugged CL125/150 2"-30" Wafer CL125/150 36"-48" Flanged CL125/150
Connections	ANSI B16.1 Class 125/ANSI B16.5 Class 150
Design	API 609
Lay Length	API 609
Testing	API 598 MSS SP-67
Leakage	100 PSIG ANSI FCI 70-2 Class VI 150 PSIG ANSI FCI 70-2 Class VI 200 PSIG ANSI FCI 70-2 Class VI
Shutoff	Maximum Allowable 250psig CWP
Temperature	-30°F to 375°F
Bonnet	ISO 5221

RESISTANCE GUIDE

Designation	Common Names	Composition	Min/Max Temperature Range	General Properties	Resistant to:	Attacked by:
EPDM	EPDM, EPM	Ethylene-propylene-diene Monomer	-40F/250F	Excellent ozone, chemical, and aging resistance. Poor resistance to petroleum-based fluids	Animal and vegetable oils, ozone, strong and oxidizing chemicals.	Mineral oils and solvents, aromatic hydrocarbons
NBR	NBR, Buna-N	Nitrile-butadiene	-30F/225F	Excellent resistance to petroleum-based fluids. Good physical properties	Many hydrocarbons, fats, oils, greases, hydraulic fluids, chemicals	Ozone, ketones, esters, aldehydes, chlorinated and nitro hydrocarbons
FPM	FPM, Viton®	Hexafluoropropylene-vinylidene fluoride	-10F/400F	Excellent oil and air resistances both at low and high temperatures. Very good chemical resistance	All aliphatic, aromatic, and halogenated hydrocarbons, acids, animal and vegetable oils	Ketones, low molecular weight esters and nitro containing compounds
PTFE	PTFE, Teflon™	Polytetrafluoro-ethylene	-100F/450F	Excellent abrasion resistance and chemically inert	Acids, harsh inorganic and organic chemicals, oils, oxidizing agents, and solvents	Molten alkali metals and fluorine at high temperatures

MATERIALS OF CONSTRUCTION

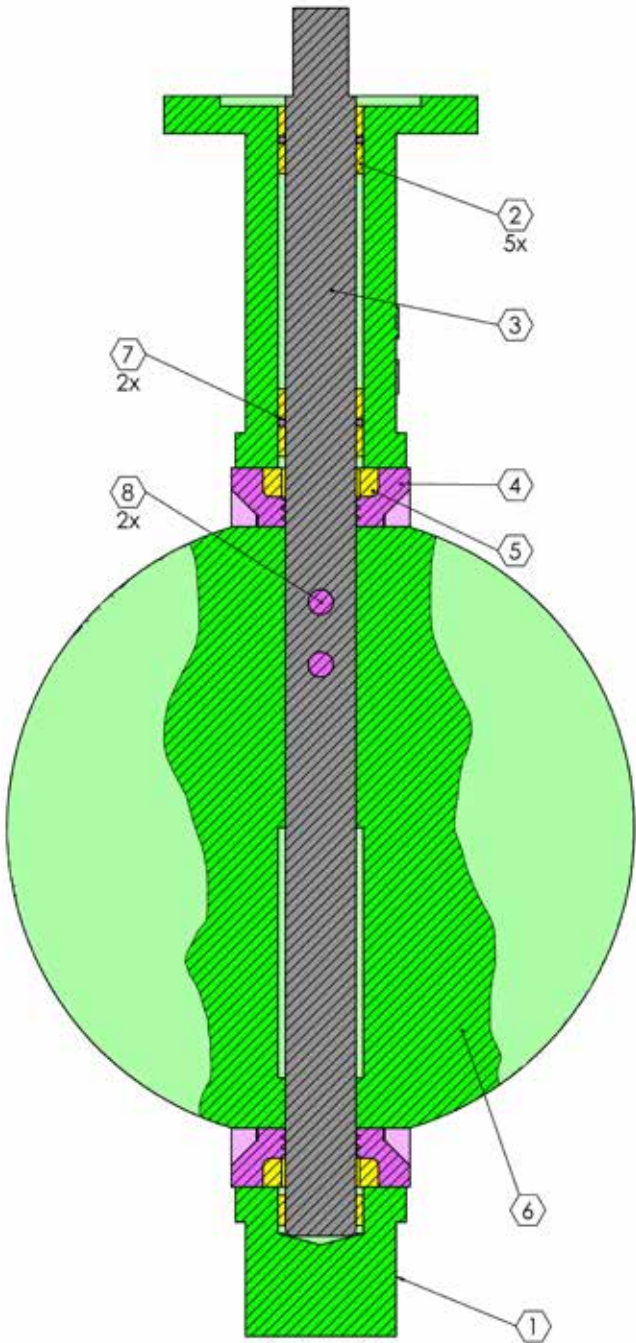

Item	Description	Materials Available	Standard
1	Body	Ductile Iron*	ASTM A536 65-45-12
		Cast Iron	ASTM A126 Class B
2	Bushings	PTFE*	
		Lubricated Bronze	
3	Shaft	Stainless 416*	ASTM A276 416
		Stainless 316	ASTM A276 316
		Stainless 304	ASTM A276 304
4	Seat	EPDM*	
		Buna-N*	
		Neoprene	
		Hypalon	
		Viton	
5	Seat Backer	Phenolic	
6	Disc	Stainless 304*	ASTM A351 CF8
		Stainless 316	ASTM A351 CF8M
		Aluminum Bronze	ASTM B148 C95400
		Ductile Iron	ASTM A536 65-45-12
7	O-Rings	Nylon Coated Ductile Iron	ASTM A536 65-45-12
		Same as Seat	
8	Pins	Stainless 316*	ASTM A276 316
		Monel	
NS	Tag	Aluminum*	UV Screen Printed

* Standard Material Option
(30" and larger have lower cap)



LUGGED/WAFER VALVE BARESTEM DIMENSIONS (IMPERIAL)

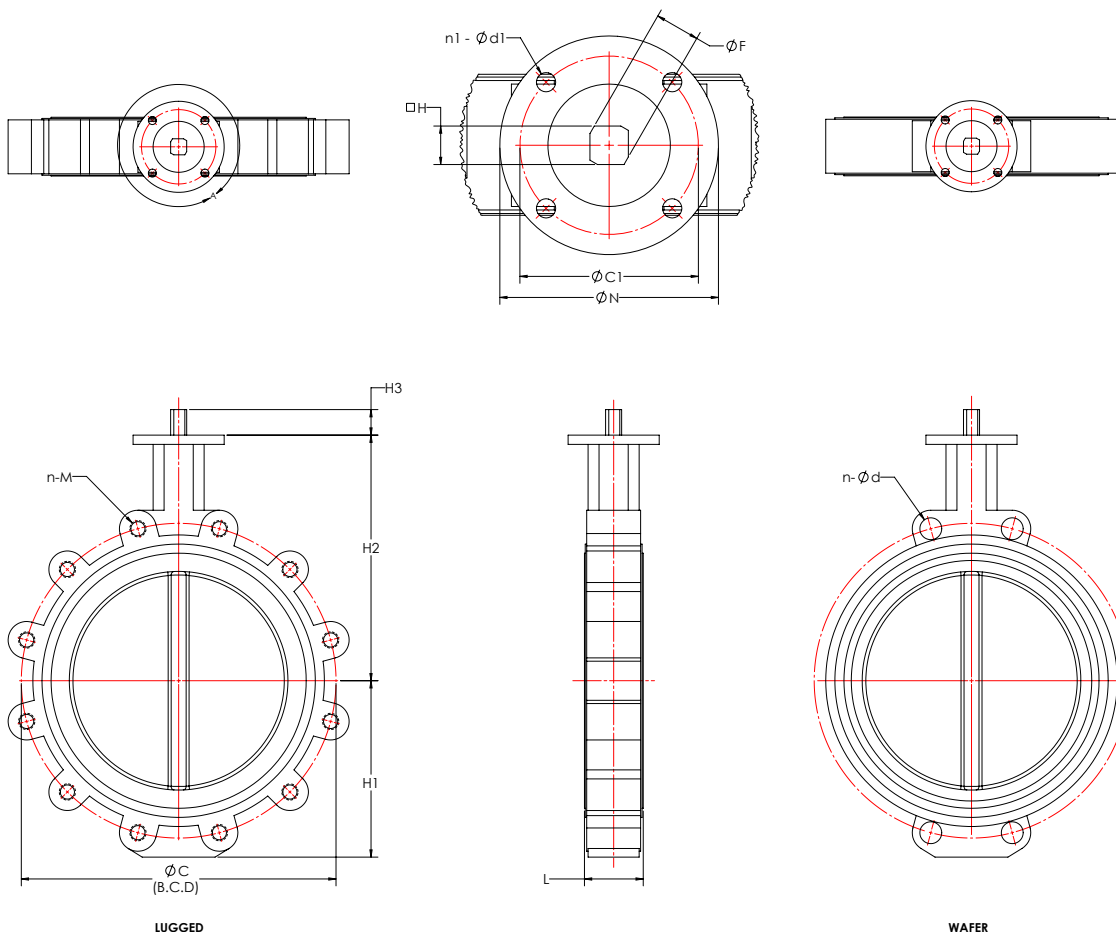

PAGE 6

SIZE	H1	H2	H3	L	C	n	M	d	ISO	C1	N	n1	d1	F	H
2"	3.15	6.34	1.142	1.693	4.75	4	5/8"-11UNC	0.75	F05	1.97	2.6	4	0.32	0.476	0.354
2.5"	3.50	6.89	1.142	1.811	5.50	4	5/8"-11UNC	0.75	F05	1.97	2.6	4	0.32	0.476	0.354
3"	3.74	7.13	1.142	1.811	6.00	4	5/8"-11UNC	0.75	F05	1.97	2.6	4	0.32	0.476	0.354
4"	4.49	7.87	1.142	2.047	7.50	8	5/8"-11UNC	0.75	F07	2.76	3.5	4	0.39	0.555	0.433
5"	5.00	8.39	1.142	2.205	8.50	8	3/4"-10UNC	0.88	F07	2.76	3.5	4	0.39	0.713	0.551
6"	5.47	8.90	1.142	2.205	9.50	8	3/4"-10UNC	0.88	F07	2.76	3.5	4	0.39	0.713	0.551
8"	6.89	10.24	1.378	2.362	11.75	8	3/4"-10UNC	0.88	F10	4.02	4.9	4	0.47	0.870	0.669
10"	7.99	11.50	1.378	2.677	14.25	12	7/8"-9UNC	1.00	F10	4.02	4.9	4	0.47	1.106	0.866
12"	9.53	13.27	1.378	3.071	17.00	12	7/8"-9UNC	1.00	F10	4.02	4.9	4	0.47	1.106	0.866
14"	10.51	14.49	1.772	3.071	18.75	12	1"-8UNC	1.12	F10	4.02	4.9	4	0.47	1.110	0.866
16"	11.69	15.75	2.016	4.016	21.25	16	1"-8UNC	1.12	F14	5.51	6.9	4	0.71	1.110	0.866/ 1.063 ⁽³⁾
18"	12.52	16.61	2.016	4.488	22.75	16	1 1/8"-7UNC	1.25	F14	5.51	6.9	4	0.71	1.425	1.063
20"	13.70	18.90	2.528	5.000	25.00	20	1 1/8"-7UNC	1.25	F14	5.51	6.9	4	0.71	1.425	1.063
24"	17.48	22.13	2.764	6.063	29.50	20	1 1/4"-7UNC	1.38	F16	6.50	8.3	4	0.87	1.898	1.417
30"	19.7	25.4	2.60	6.500	36.00	28	1 1/4"-7UNC	1.38	F25	10.00	11.8	8	0.71	2.560	(2)
36"	25.1	28.3	4.65	8.000	42.75	32	1 1/2"-6UNC	(1)	F25	10.00	11.8	8	0.71	2.953	(2)

1) 36" not available in wafer
 2) 30" and larger have round bore with keyway, consult VSI
 3) 16" may be 0.866" or 1.063", consult VSI

LUGGED/WAFER VALVE BARESTEM DIMENSIONS (METRIC)

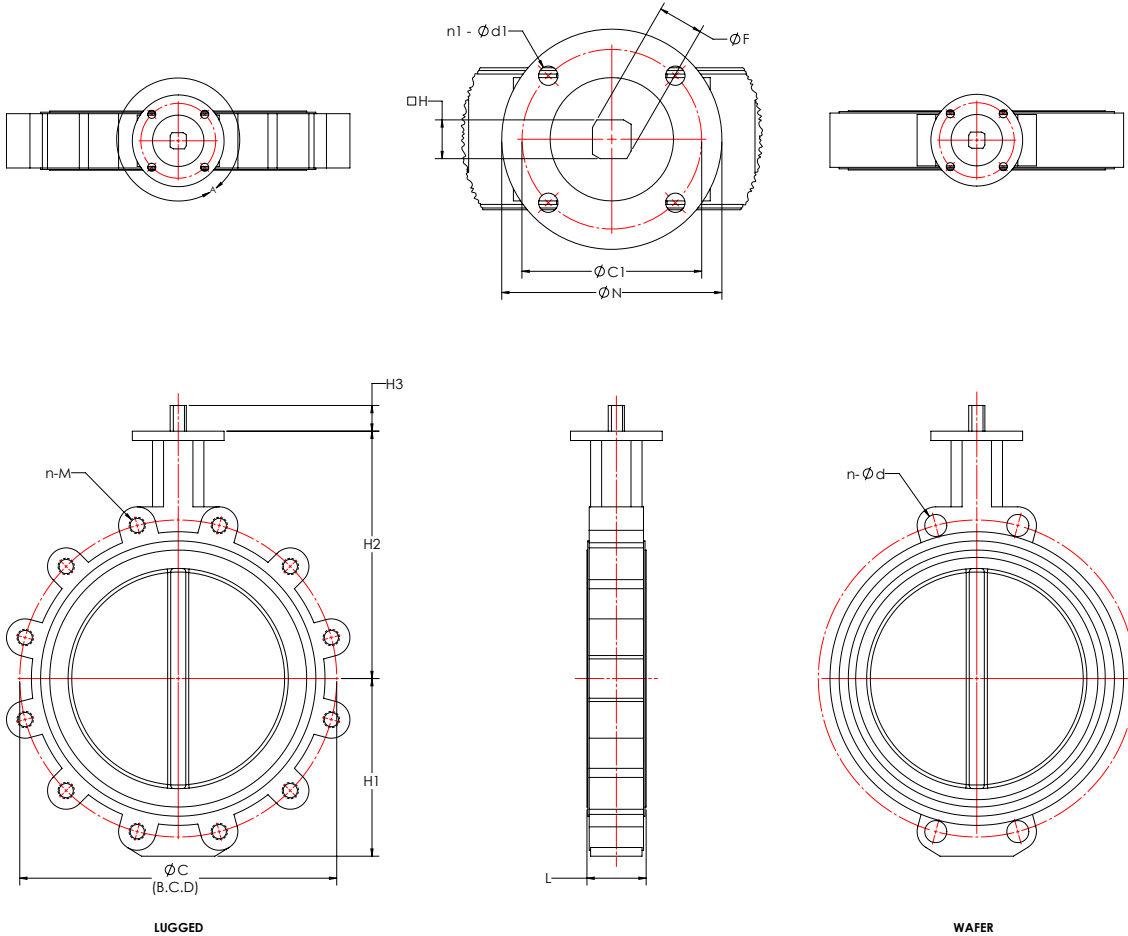

SIZE	H1	H2	H3	L	C	n	M	d	ISO	C1	N	n1	d1	F	H
2"	80	161	29	43	120.6	4	5/8"-11UNC	19	F05	50	65	4	8	12.1	9
2.5"	89	175	29	46	139.7	4	5/8"-11UNC	19	F05	50	65	4	8	12.1	9
3"	95	181	29	46	152.4	4	5/8"-11UNC	19	F05	50	65	4	8	12.1	9
4"	114	200	29	52	190.5	8	5/8"-11UNC	19	F07	70	90	4	10	14.1	11
5"	127	213	29	56	215.9	8	3/4"-10UNC	22.4	F07	70	90	4	10	18.1	14
6"	139	226	29	56	241.3	8	3/4"-10UNC	22.4	F07	70	90	4	10	18.1	14
8"	175	260	35	60	298.4	8	3/4"-10UNC	22.4	F10	102	125	4	12	22.1	17
10"	203	292	35	68	361.9	12	7/8"-9UNC	25.4	F10	102	125	4	12	28.1	22
12"	242	337	35	78	431.8	12	7/8"-9UNC	25.4	F10	102	125	4	12	28.1	22
14"	267	368	45	78	476.2	12	1"-8UNC	28.4	F10	102	125	4	12	28.2	22
16"	297	400	51.2	102	539.7	16	1"-8UNC	28.4	F14	140	175	4	18	28.2	22/ 27 ⁽³⁾
18"	318	422	51.2	114	577.8	16	1 1/8"-7UNC	31.8	F14	140	175	4	18	36.2	27
20"	348	480	64.2	127	635.0	20	1 1/8"-7UNC	31.8	F14	140	175	4	18	36.2	27
24"	444	562	70.2	154	749.3	20	1 1/4"-7UNC	35.1	F16	165	210	4	22	48.2	36
30"	499	646	66	165	914.4	28	1 1/4"-7UNC	35.1	F25	254	300	8	18	65.1	(2)
36"	637	720	118	203	1086	32	1 1/2"-6UNC	(1)	F25	254	300	8	18	75.0	(2)

1) 36" not available in wafer

2) 30" and larger have round bore with keyway, consult VSI

3) 16" may be 22 or 27, consult VSI



FLANGED VALVE BARESTEM DIMENSIONS

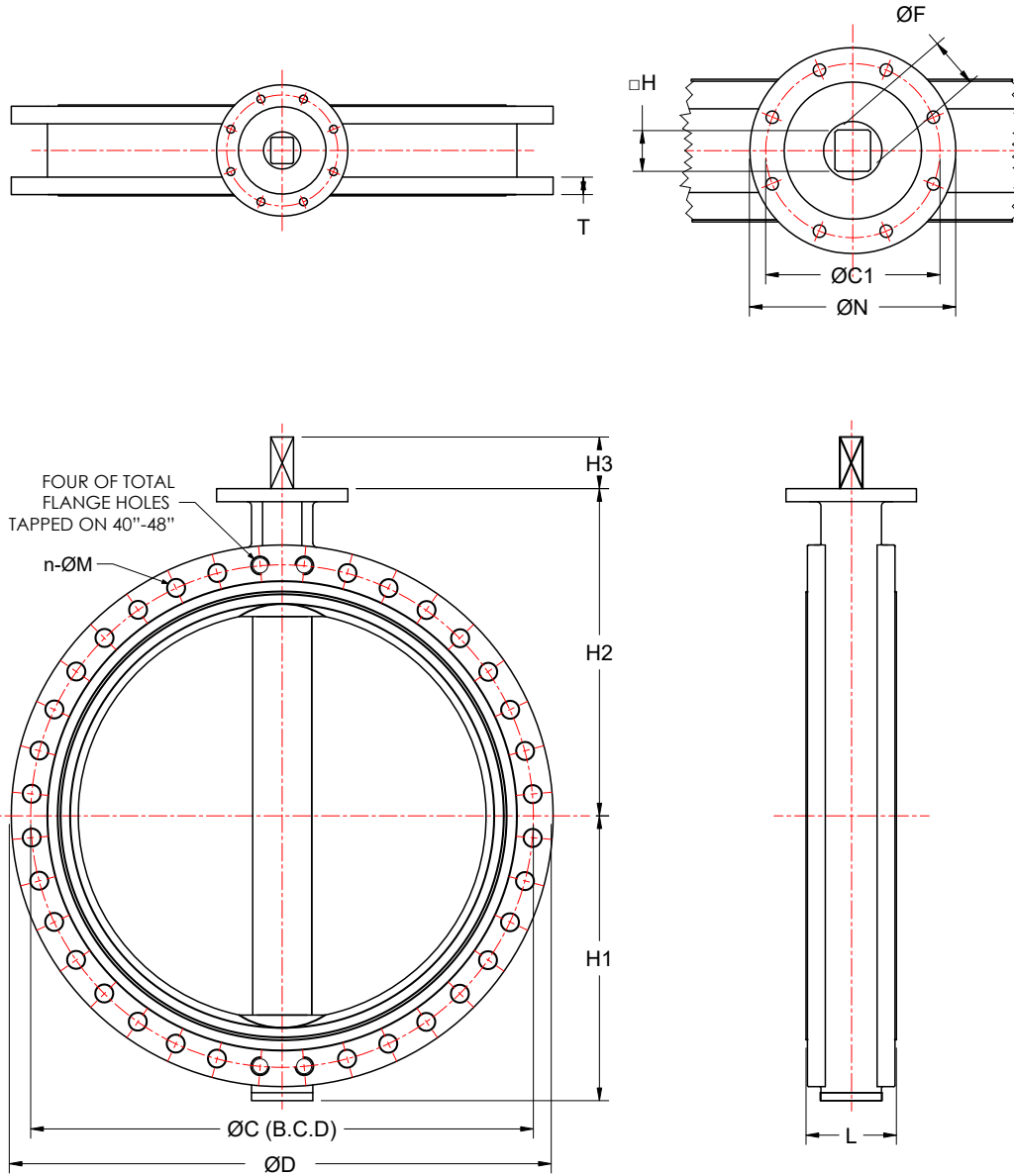

FOUR OF TOTAL
FLANGE HOLES
TAPPED ON 40"-48"

PAGE 8

SIZE	H1	H2	H3	L	C	D	n	M	ISO	C1	N	n1	d1	F	H
24"	16.54	22.13	2.764	6.063	29.50	33.1	20	1.38	F16	6.50	8.3	4	0.87	1.898	1.417
30"	19.65	25.43	3.386	6.575	36.00	38.0	28	1.38	F25	10.00	11.8	8	0.71	2.370	1.811
36"	22.17	28.35	4.646	7.992	42.75	43.9	32	1.63	F25	10.00	11.8	8	0.71	2.843	2.165
40"	24.72	31.50	5.118	8.583	47.25	48.4	36	1.63	F25	10.00	11.8	8	0.71	2.843	2.165
42"	29.13	32.48	5.906	9.882	49.50	52.8	36	1.63	F25	10.00	11.8	8	0.71	2.843	2.165
48"	33.23	37.00	5.906	10.000	56.00	57.3	44	1.63	F30	11.73	13.8	8	0.87	3.866	2.953

100 PSI VALVES WITH SERIES 1000-X ELECTRIC ACTUATOR

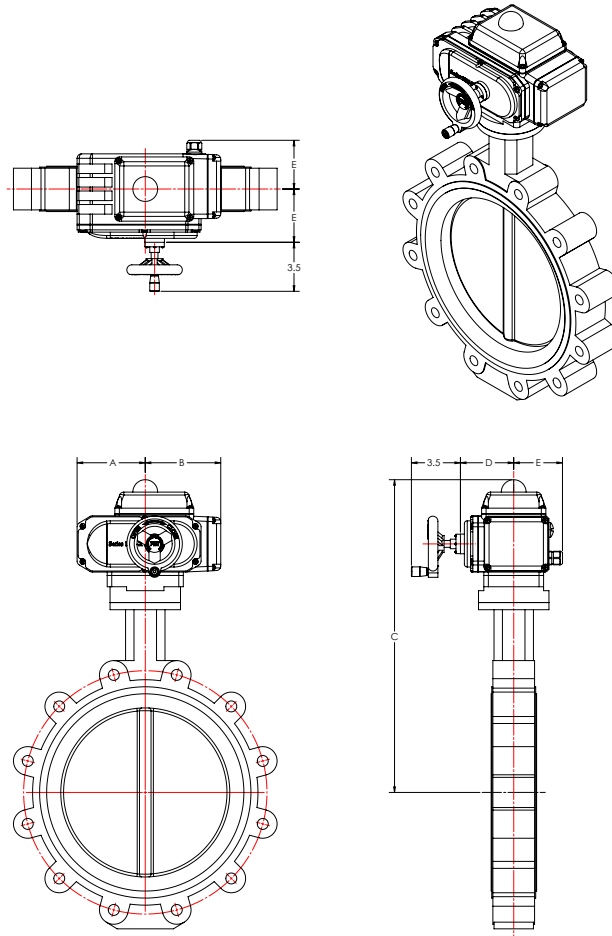

SIZE	2-POS ACTUATOR	MODULATING ACTUATOR	A	B	C	D	E
2"	1005-XL*	1005/S-XL*	3.27	3.03	12.7	2.48	2.87
2-1/2"	1005-XL*	1005/S-XL*	3.27	3.03	13.2	2.48	2.87
3"	1005-XL*	1005/S-XL*	3.27	3.03	13.5	2.48	2.87
4"	1005-XL*	1005/S-XL*	3.27	3.03	14.2	2.48	2.87
5"	1005-XL*	1005/S-XL*	3.27	3.03	14.7	2.48	2.87
6"	1010-X	1010/S-X	3.86	3.86	15.6	2.81	2.90
8"	1020-X	1020/S-X	4.76	5.28	18.8	3.72	3.40
10"	1020-X	1020/S-X	4.76	5.28	20.1	3.72	3.40
12"	1040-X	1040/S-X	4.76	5.28	21.9	3.72	3.40
14"	1040-X	1040/S-X	4.76	5.28	23.1	3.72	3.40
16"	1100-X	1100/S-X	5.83	6.38	25.4	5.12	4.37
18"	1100-X	1100/S-X	5.83	6.38	26.2	5.12	4.37
20"	1160-X	1160/S-X	5.83	6.38	28.5	5.12	4.37
24"	1250-X	1250/S-X	5.83	6.38	31.7	5.12	4.37

*HANDWHEEL NOT AVAILABLE ON 1005-XL OR 1005/S-XL; 1010-X OR 1010/S-X MAY BE USED WHERE HANDWHEEL IS NEEDED. CONSULT FOR DIMENSIONS.



150/200 PSI VALVES WITH SERIES 1000-X ELECTRIC ACTUATOR

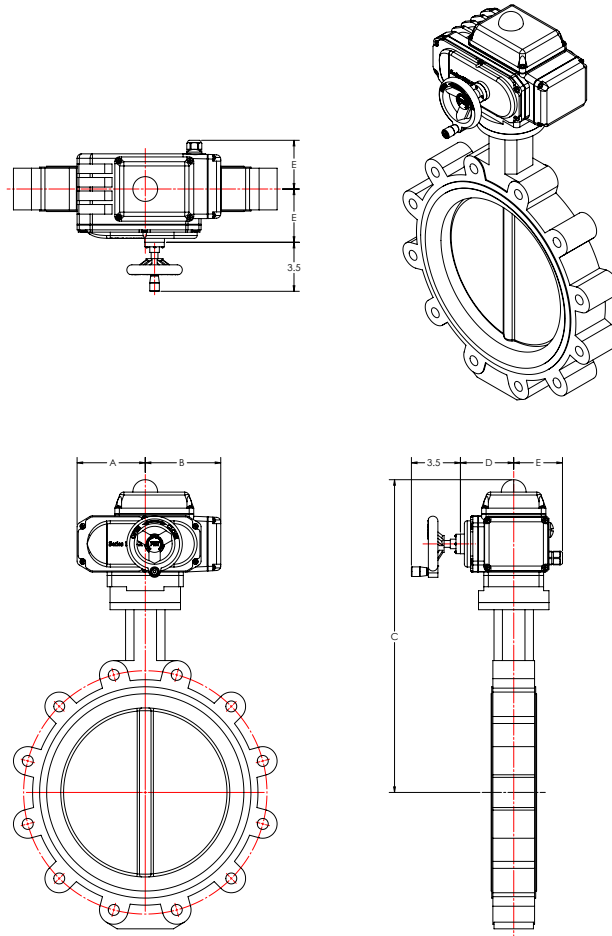

SIZE	2-POS ACTUATOR	MODULATING ACTUATOR	A	B	C	D	E
2"	1005-XL*	1005/S-XL*	3.27	3.03	12.7	2.48	2.87
2-1/2"	1005-XL*	1005/S-XL*	3.27	3.03	13.2	2.48	2.87
3"	1005-XL*	1005/S-XL*	3.27	3.03	13.5	2.48	2.87
4"	1010-X	1010/S-X	3.27	3.03	14.2	2.48	2.87
5"	1010-X	1010/S-X	3.86	3.86	15.1	2.81	2.90
6"	1010-X	1010/S-X	3.86	3.86	15.6	2.81	2.90
8"	1020-X	1020/S-X	4.76	5.28	18.8	3.72	3.40
10"	1040-X	1040/S-X	4.76	5.28	20.1	3.72	3.40
12"	1040-X	1040/S-X	4.76	5.28	21.9	3.72	3.40
14"	1060-X	1060/S-X	4.76	5.28	23.1	3.72	3.40
16"	1100-X	1100/S-X	5.83	6.38	25.4	5.12	4.37
18"	1160-X	1160/S-X	5.83	6.38	26.2	5.12	4.37
20"	1160-X	1160/S-X	5.83	6.38	28.5	5.12	4.37
24"	1250-X	1250/S-X	5.83	6.38	31.7	5.12	4.37

*HANDWHEEL NOT AVAILABLE ON 1005-XL OR 1005/S-XL; 1010-X OR 1010/S-X MAY BE USED WHERE HANDWHEEL IS NEEDED. CONSULT FOR DIMENSIONS.

100 PSI VALVES WITH SERIES C PNEUMATIC ACTUATORS

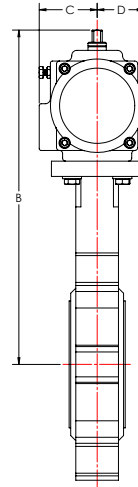
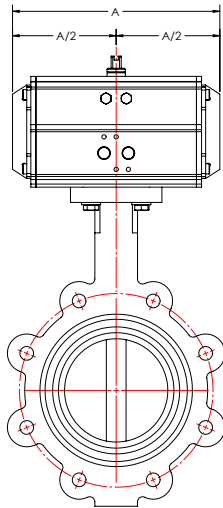
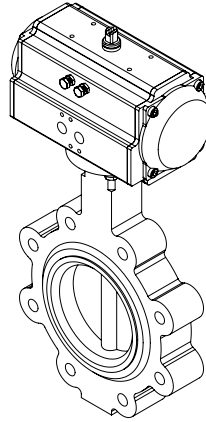
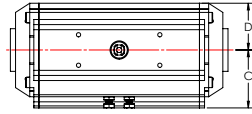

SIZE	DA ACTUATOR	A	B	C	D
2"	C-DA063	6.61	10.6	1.85	1.42
2-1/2"	C-DA063	6.61	11.1	1.85	1.42
3"	C-DA063	6.61	11.4	1.85	1.42
4"	C-DA083	7.87	13.1	2.24	1.81
5"	C-DA083	8.03	13.5	2.24	1.81
6"	C-DA092	10.15	14.4	2.30	1.79
8"	C-DA125	11.85	17.1	2.93	2.66
10"	C-DA125	11.85	18.4	2.93	2.66
12"	C-DA140	15.35	20.8	3.03	2.95
14"	C-DA160	18.03	23.0	3.43	3.43
16"	C-DA190	20.67	26.0	4.06	4.06
18"	C-DA190	20.67	26.9	4.06	4.06
20"	C-DA210	20.94	30.1	4.45	4.45
24"	C-DA270	28.43	36.2	5.79	5.79

SIZE	SR ACTUATOR	A	B	C	D
2"	C-SR063	6.61	10.6	1.85	1.42
2-1/2"	C-SR083	8.03	12.0	2.24	1.81
3"	C-SR083	8.03	12.2	2.24	1.81
4"	C-SR092	10.15	13.4	2.30	1.79
5"	C-SR092	10.31	13.8	2.30	1.79
6"	C-SR125	11.69	16.0	2.93	2.66
8"	C-SR140	15.35	17.8	3.03	2.95
10"	C-SR140	15.35	19.1	3.03	2.95
12"	C-SR160	18.03	21.8	3.43	3.43
14"	C-SR190	20.67	24.7	4.06	4.06
16"	C-SR210	20.94	27.0	4.45	4.45
18"	C-SR240	23.70	29.2	5.12	5.12
20"	C-SR270	28.43	32.9	5.79	5.79



150/200 PSI VALVES WITH SERIES C PNEUMATIC ACTUATORS

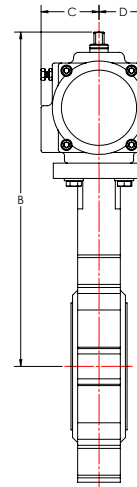
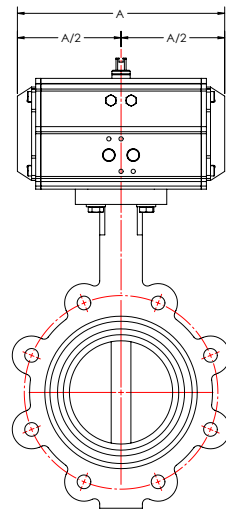
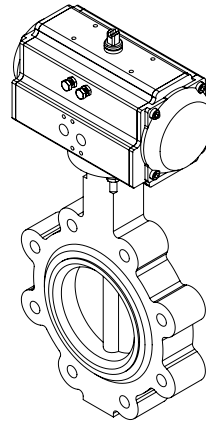
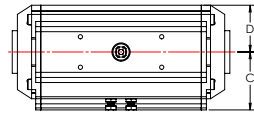

PAGE 12

SIZE	DA ACTUATOR	A	B	C	D
2"	C-DA063	6.61	10.6	1.85	1.42
2-1/2"	C-DA063	6.61	11.1	1.85	1.42
3"	C-DA063	6.61	11.4	1.85	1.42
4"	C-DA083	8.03	12.9	2.24	1.81
5"	C-DA092	10.31	13.8	2.30	1.97
6"	C-DA105	10.55	14.9	2.52	2.26
8"	C-DA125	11.85	17.1	2.93	2.66
10"	C-DA140	15.35	19.1	3.03	2.95
12"	C-DA160	18.03	21.8	3.43	3.43
14"	C-DA160	18.03	23.0	3.43	3.43
16"	C-DA190	20.67	26.0	4.06	4.06
18"	C-DA240	23.70	29.2	5.12	5.12
20"	C-DA240	23.70	31.5	5.12	5.12
24"	C-DA300	29.21	37.0	6.38	6.38

SIZE	SR ACTUATOR	A	B	C	D
2"	C-SR063	6.61	10.6	1.85	1.42
2-1/2"	C-SR083	8.03	12.0	2.24	1.81
3"	C-SR083	8.03	12.2	2.24	1.81
4"	C-SR092	10.31	13.2	2.30	1.79
5"	C-SR125	11.85	15.3	2.93	2.66
6"	C-SR125	11.85	15.8	2.93	2.66
8"	C-SR140	15.35	17.8	3.03	2.95
10"	C-SR160	18.03	20.0	3.43	3.43
12"	C-SR190	20.67	23.5	4.06	4.06
14"	C-SR190	20.67	24.7	4.06	4.06
16"	C-SR240	23.70	28.3	5.12	5.12
18"	C-SR300	29.21	31.5	6.38	6.38

3-WAY BUTTERFLY VALVE ASSEMBLIES

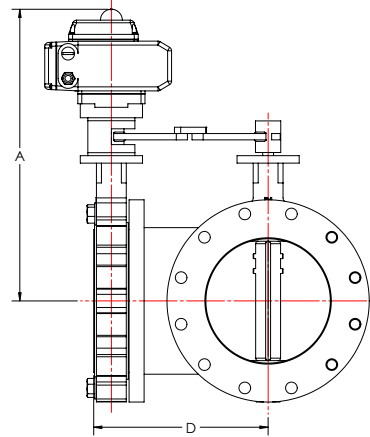
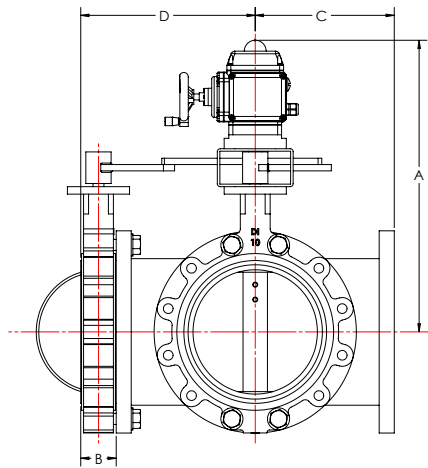
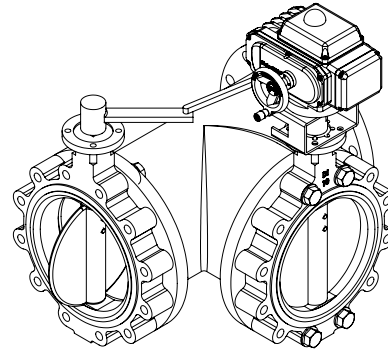
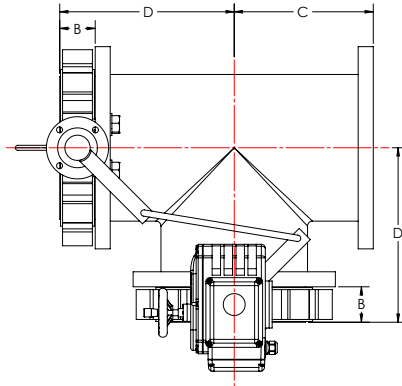

SIZE	A*	B	C	D
2"	14.7	1.69	4.5	6.2
2-1/2"	15.2	1.81	5.0	6.8
3"	15.5	1.81	5.5	7.3
4"	18.0	2.05	6.5	8.6
5"	18.5	2.21	7.5	9.7
6"	20.4	2.21	8.0	10.2
8"	22.8	2.36	9.0	11.4
10"	24.1	2.68	11.0	13.7
12"	25.9	3.07	12.0	15.1
14"	27.1	3.07	14.0	17.1
16"	29.4	4.02	15.0	19.0
18"	30.2	4.49	16.5	21.0
20"	32.5	5.00	18.0	23.0

*Height varies according to actuator chosen and accessories used
 -Other 3-way butterfly valve configurations available



FLOW COEFFICIENTS AND DATA

SIZE	Valve Flow Coefficient (Cv)								
	Valve Rotation in Degrees								
	10°	20°	30°	40°	50°	60°	70°	80°	90°
2"	0.1	5	12	24	45	64	90	125	135
2-1/2"	0.2	8	20	37	65	98	144	204	220
3"	0.3	12	22	39	70	116	183	275	302
4"	0.5	17	36	78	139	230	364	546	600
5"	0.8	29	91	133	237	392	620	930	1022
6"	2	45	95	205	366	605	958	1437	1579
8"	3	89	188	405	727	1202	1903	2854	3136
10"	4	151	320	694	1237	2047	3240	4859	5340
12"	5	234	495	1072	1911	3162	5005	7507	8250
14"	6	338	715	1549	2761	4568	7230	10844	11917
16"	8	464	983	2130	3797	6282	9942	14913	16388
18"	11	615	1302	2822	5028	8320	13168	19752	21705
20"	14	791	1674	3628	6465	10698	16931	25396	27908
24"	22	1222	2587	5605	9989	16528	26157	39236	43116
30"	30	1652	3986	7080	11328	18090	28844	43003	52458
36"	50	2775	5936	9790	15572	25053	40086	59667	77122
42"	63	3502	7879	12997	21010	35016	54584	83421	103965
48"	84	4651	10365	17010	27242	43853	70431	108968	134269

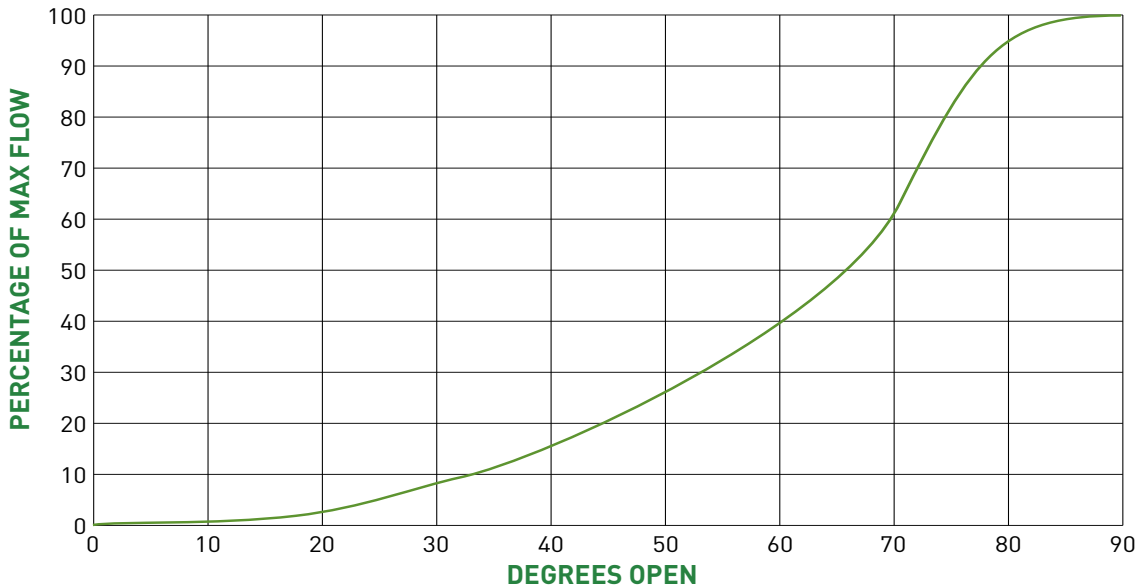



VALVE WEIGHTS (LUGGED VALVES)

SIZE	2"	2-1/2"	3"	4"	5"	6"	8"	10"	12"
LBS	7.4	9.1	9.6	15.0	20.6	23.7	38.0	57.0	87.0
KGS	3.35	4.13	4.35	6.80	9.34	10.75	17.23	25.85	39.46

SIZE	14"	16"	18"	20"	24"	30"	36"	42"	48"
LBS	135	203	243	338	490	930	1770	2470	3130
KGS	61.2	92.1	110.2	153.3	222.3	421.8	802.9	1120	1420

OPERATING TORQUES

Seat Torque (inlbs) at Pressure (PSI)

SIZE	Undercut Design Disc			Standard Disc		
	0PSI	50PSI	100PSI	100PSI	150PSI	200PSI
2"	74	77	80	80	80	89
2-1/2"	99	104	106	131	133	159
3"	109	116	124	156	160	195
4"	204	218	230	273	266	301
5"	245	265	283	360	372	460
6"	384	426	469	570	567	664
8"	524	594	664	823	832	991
10"	764	864	956	1280	1372	1788
12"	1143	1327	1513	1981	2089	2655
14"	1742	2066	2390	3237	3496	-
16"	2775	2906	3426	4732	5177	-
18"	4660	4890	5753	7642	8142	-
20"	5670	5950	7000	9351	10001	-
24"	10251	10758	12656	17898	19886	-
30"	17946	18832	22155	29510	31500	-
36"	31673	32991	38982	47204	55425	-
42"	48728	56037	64159	77690	91221	-
48"	62534	75528	89335	108175	127016	-

No safety factor included. Torques are with water as operating fluid, dry media may require a higher safety factor.



PRESSURE/TEMPERATURE RATINGS CHART

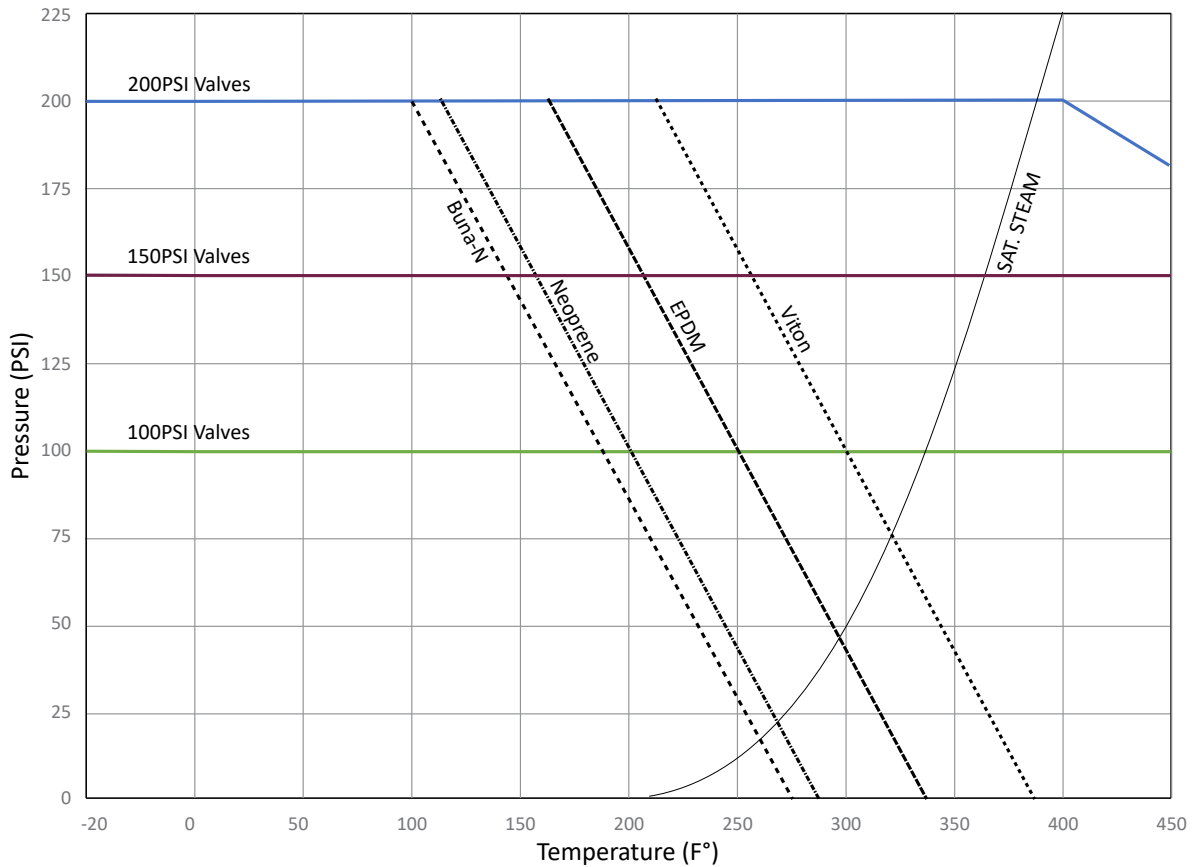

PAGE 16

WARRANTY

This limited warranty applies in the United States to products manufactured by VSI, LLC. VSI, LLC. warrants the product purchased from it or its authorized reseller to be free from defects in material and workmanship under normal use during the two year warranty period from the date of its purchase. Other products not manufactured by VSI, LLC. which are provided as part of an assembly may carry additional warranties from that manufacturer or supplier.

During the warranty period, VSI, LLC. will repair or replace defective parts of the product, or, at VSI, LLC. sole option, issue a credit for the original purchase price of the product. Repaired or replaced product will be warranted hereunder only for the remaining portion of the original warranty period. All exchanged products under this Limited Warranty will become the property of VSI, LLC. A proper Return Material Authorization (RMA) number will have to be obtained for all products to be returned under this Limited Warranty. Any claim under this Limited Warranty must include a description of the problem encountered and any relevant information that may assist VSI, LLC. in the replication or resolution of the problem.

This Limited Warranty is transferable during its term to the end user of the product. Any transfer shall not extend or alter the terms of this Limited Warranty.

This Limited Warranty extends only to products purchased from VSI, LLC. or its authorized reseller and does not extend to any product that has been damaged or rendered defective as a result of (a) modification, repair, alteration or improper installation by any person other than VSI, LLC. or its authorized representative; (b) unreasonable or improper use or storage, use beyond rated conditions, operation other than per VSI, LLC. or the manufacturer's instructions, or being otherwise subjected to improper maintenance, negligence or accident; or (c) any use of the product after purchaser has knowledge of any defect in the product.

The warranties provided above are in lieu of and exclude all other warranties, statutory, express or implied, including without limitation any warranty or merchantability or fitness for a particular purpose. VSI, LLC. expressly disclaims all warranties not stated in this limited warranty. Any implied warranties that may be imposed by law are limited to the terms of this limited warranty.

VSI, LLC. warranty liability shall not exceed the original purchase price of the defective product. VSI, LLC. is not liable for any damages caused by the product or other products or the failure of the product or other products to perform, including any lost profits, lost savings, incidental or consequential damages. VSI, LLC. is not responsible for charges resulting from the removal and/or replacement of the product. VSI, LLC. is not liable for any claims made by third parties or by the purchaser for a third party. This limitation applies whether damages are sought, or a claim is made, under the Limited Warranty or as a tort claim, product liability claim, contract claim, or any other claim. This limitation cannot be waived by any person. This limitation of liability will be effective even if VSI, LLC. or its authorized representative has been advised by the purchaser of the possibility of such damages.

SAMPLE SPECIFICATION

1. Resilient Seat Butterfly Valves

1.1. This specification covers the design, manufacture, and testing of resilient seat butterfly valves 2-inch (50 mm) to 30-inch (750mm) under shell pressures of up to 200 psig (1,379 kPa).

2. CONNECTIONS

2.1. Valves shall be of the wafer lugged flange type for installation between ANSI B16.5, Class 150 flanges.

2.2. All valves shall be fully lugged type with drilled and tapped holes.

2.3. Lay length for valves shall conform to API 609

3. MARKINGS

3.1. Each valve shall be marked with the manufacturer's name and valve size cast into the body of the valve. Lettering shall be a minimum of 1/2 inch tall and project 1/10 inch from body.

3.2. Valves shall be equipped with a tag identifying the size, the model designation, the pressure rating, the seat material, and a unique traceable serial number in addition to manufacturer's name and contact information.

4. DESIGN

4.1. Valves shall be designed and suitable for use in water, low pressure steam, and glycol water mixes for HVAC control

4.2. Valves shall be designed and tested to ANSI Class VI leakage rate.

4.3. The valve shall be rated to an allowable shutoff pressure of 200psi or 100psi as specified by the engineer. All valves shall be bi-directionally rated to the allowable shutoff pressure.

4.4. Valve design, including face to face dimensions, shall comply with API 609 requirements

4.5. The shell thickness shall be designed to conform to ASME B16.42 pressure and temperature requirements

4.6. Stem shall be of a one-piece design and of the blowout proof style.

4.7. Stem shall be retained by taper pins or by a spring clip and washer.

4.8. No part of the valve body or stem shall be exposed to the line media. Only the disc and the seat may be exposed to the line media.

4.9. The seat shall totally encapsulate the body isolating it from the line media and shall incorporate a means to seal the valve to the companion pipe flange with no gaskets required.

4.10. The seat shall have integrally molded seals at the upper and lower shaft penetration to prevent line media from fouling the bearings.

4.11. All valves shall have at minimum one bearing in the lower trunnion and two in the upper trunnion.

4.12. The valves shall be equipped with a mounting area conforming to International Organization of Standardization (ISO) 5211 so that any standardized lever, gearbox, pneumatic, hydraulic, or electric actuator may be installed as required by application. There shall be sufficient clearance to directly mount standardized operators with easily accessible fasteners.

5. MATERIALS

5.1. The valve body shall be constructed of ASTM A536 65-45-12 Ductile Iron for all valves

5.2. The valve disc shall be cast from ASTM A351 CF8 Stainless Steel 304 or ASTM A351 CF8M Stainless Steel 316 as specified by the engineer. The disc edge shall be ground and polished.

5.3. The seat shall be made of peroxide cured EPDM or Buna-N. Viton seats are required for installations where operating temperatures reach or exceed 250°F

5.4. The valve stem shall be constructed of stainless steel material with a minimum Yield Strength of 35,000 PSI. Valve stems shall be ASTM A276 Stainless Steel 416

5.5. The valve body shall be coated with a heat cured epoxy

6. MANUFACTURER

6.1. Resilient seat butterfly valves shall be VSI Series 2100 Butterfly Valves as manufactured by Valve Solutions, Inc., Alpharetta, GA USA or approved equal

6.2. All valves shall be warranted by manufacturer for a minimum of 24 months.



PART NUMBER MATRIX

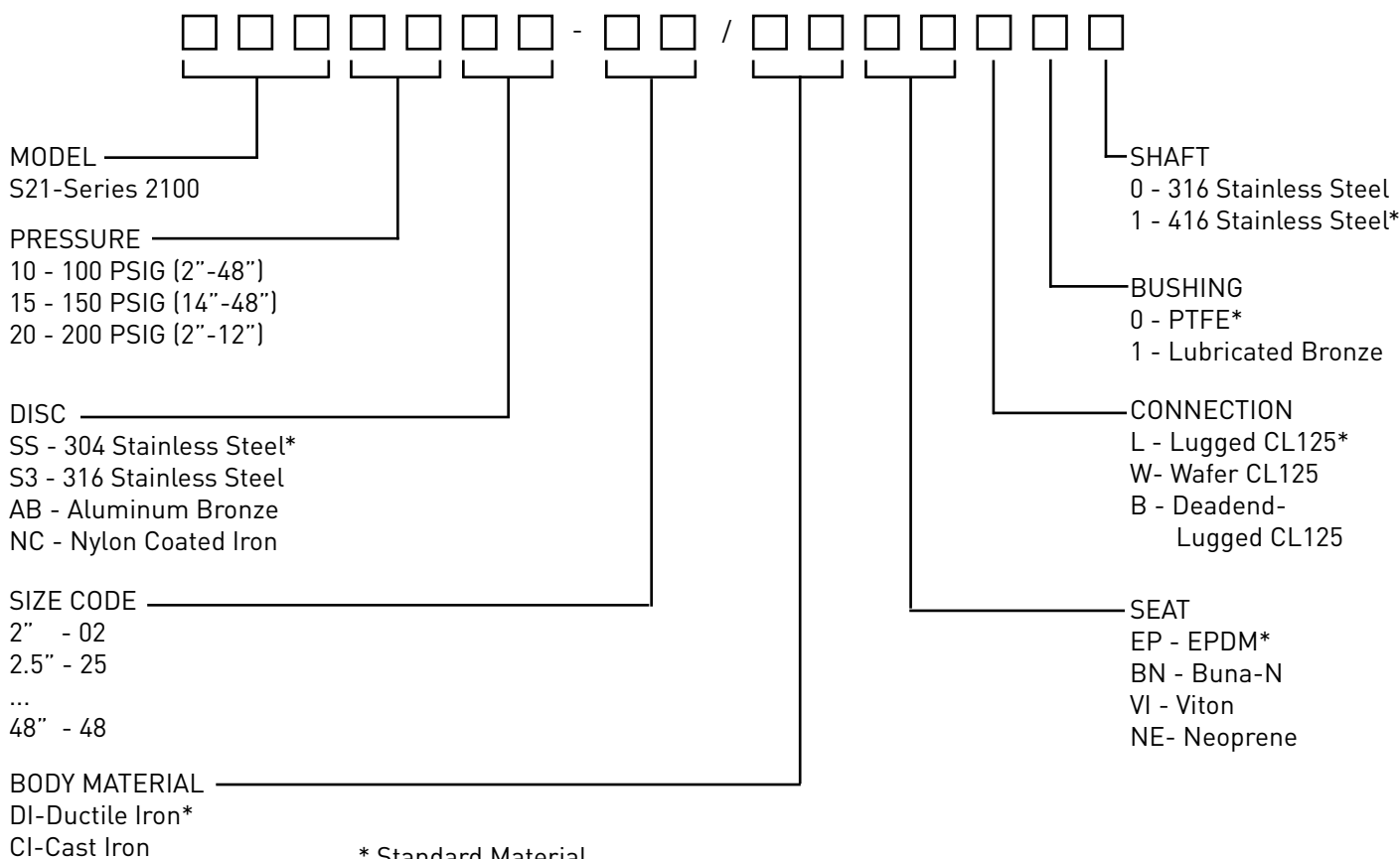

EXAMPLE:

S2110SS-04/DIEPL01

A Series 2100, 100psig operating pressure, 304 Stainless Steel Disc, Size 4", Ductile Iron Body, EPDM seat, Lugged CL125 connection, PTFE bearings, SS416 shaft

OTHER PART NUMBER INFORMATION

ASSEMBLIES

The part numbers above represent only the part number for the valve without any operator or accessories. When purchased with an actuator as part of an assembly the entire part number will be formatted as the valve part number, forward slash, then the actuator and accessory part numbers.

Example: S2110SS-04/C-SR092/ALS-100

The above valve is a 4" valve model S2110 with a C-SR092 spring return pneumatic actuator and ALS-100 switch-box

MANUAL OPERATORS

Sizes 2" to 6" are available with a locking lever operator, add a "L" suffix. Sizes 8" and larger are available with a worm gear and handwheel operator, add a "WH" suffix.

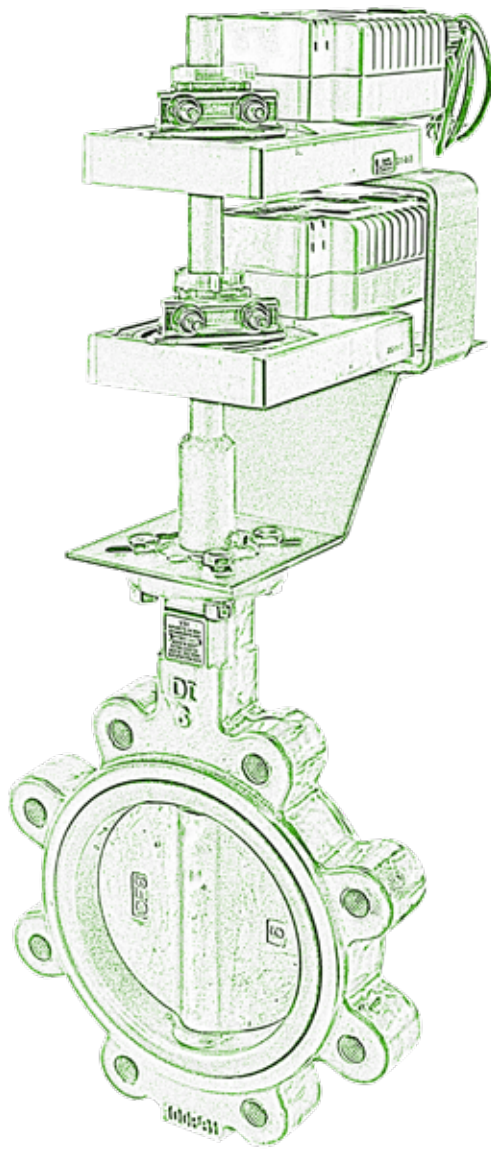

Valve Solutions, Inc
tel: 1 (770) 740 0800
fax: 1 (770) 740 8777
email: sales@valvesolutions.com

VSI

www.ValveSolutions.com

As part of a process of on-going product development, VSI reserves the right to amend or change specifications without prior notice. Published data may be subject to change. For the latest version, visit our website at www.valvesolutions.com