



# BALL VALVE - 24V DCA

## MODULATING SIEMENS DAMPER ELECTRIC ACTUATORS

### 1/2" - 3" BRASS BODY, 3-WAY BALL VALVES

### 3-WAY BALL VALVES

**STATIC PRESSURE:** 360 psi  
**CLOSE-OFF PRESSURE:** 50 psi (1/2" - 1")  
 40 psi (1.25" - 2 1/2")  
 70 psi (3")  
**TEMPERATURE:** -22°F - 250°F  
**BODY:** FORGED BRASS ASTM B283-06  
**END CONNECTIONS:** FEMALE NPT  
**BALL:** NICKEL-PLATED BRASS  
**STEM:** BRASS  
**STEM SEALS:** DUAL TEFLON SEALS AND EPDM O-RING  
**BALL SEALS:** TEFLON SEALS WITH EPDM O-RINGS  
**FLOW CHARACTERISTIC:** EQUAL PERCENTAGE  
**FLOW CHARACTERIZER:** GLASS FILLED POLYMER  
**LEAKAGE RATE:** CLASS IV  
**CONTROLLED MEDIUM:** CHILLED WATER, HOT WATER,  
 50% WATER-GLYCOL SOLUTIONS

### MODULATING DAMPER ACTUATORS

**NEMA 2 PROTECTION**  
**POWER SUPPLY:** 24VAC ± 20% 50/60Hz  
 24VDC ± 10%  
**TEMPERATURE RANGE:** -5°F to +125°F  
**RUNTIME:** 75 to 150 sec

#### POWER CONSUMPTION

**GDE.161.1P:** 3VA / 1.5W      **GMA.161.1P:** 5VA / 3.5W

#### POWER CONNECTION

1/2" CONDUIT TO 3' CABLE (18 GA)



VALVE INFORMATION				NON-SPRING RETURN	SPRING RETURN
SIZE	MODEL #	Cv	CLOSE-OFF	GDE.161.1P	GMA.161.1P
1/2"	UR3AAFB	0.33	50 PSI		
	UR3ABFB	0.59			
	UR3ACFB	1.0			
	UR3ADFB	2.4			
	UR3AEFB	4.3			
	UR3AFFB	8.0			
3/4"	UR3BAFB	0.40	50 PSI		
	UR3BBFB	0.66			
	UR3BCFB	1.3			
	UR3BDFB	2.4			
	UR3BEFB	3.8			
	UR3BFFB*	11.0			
1"	UR3CAFB	0.40	50 PSI		
	UR3CBFB	0.65			
	UR3CCFB	1.3			
	UR3CDFB	2.3			
	UR3CEFB	3.5			
	UR3CFFB	10.0			
	UR3CGFB	8.6			
	UR3CHFB	22.3			
	UR3CJFB	14.9			
	UR3CKFB	4.5			
1 1/4"	UR3DBFB*	19.4	40 PSI		
	UR3DCFB	14.7			
	UR3DDFB	4.1			
	UR3DEFB	8.7			
	UR3DFFB*	34.1			
	UR3DGFB	26.8			
1 1/2"	UR3EAFB	13.4	40 PSI		
	UR3EBFB	4.0			
	UR3ECFB	8.3			
	UR3EDFB*	32.0			
	UR3EEFB	23.5			
	UR3EFFB	61.1			
2"	UR3FAFB	23.9	40 PSI		
	UR3FBFB	56.7			
	UR3FCFB	38.2			
	UR3FDFB	108.5			
2 1/2"	UR3G1FB	38.1	40 PSI		
	UR3G2FB	74.1			
	UR3G3FB*	99.5			
3"	UR3HAFB	75.0	70 PSI		
	UR3HBFB	100.0			
	UR3HCFB	125.0			
	UR3HDFB	150.0			
	UR3HEFB	175.0			
	UR3HFFB*	200.0			



# BALL VALVE - 24V DCA

## MODULATING SIEMENS DAMPER ELECTRIC ACTUATORS

### 1/2" - 3" BRASS BODY, 3-WAY BALL VALVES

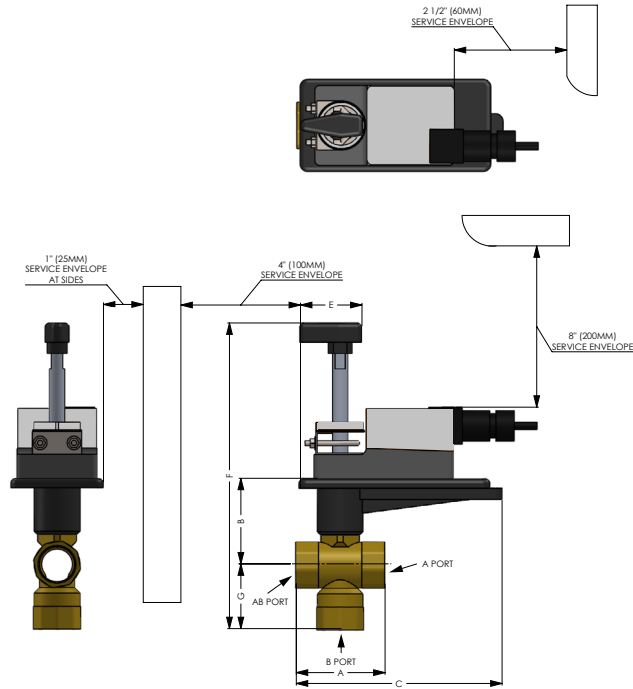

### Dimensions

VALVE SIZE	MODEL	MODEL (Cv)	A	B	C	E	F	G
1/2"	UR3A_	A(0.33), B(0.59), C(1.0), D(2.4), E(4.3), F(8.0)	2.7	3.4	7.0	2.02	9.5	2.0
3/4"	UR3B_	A(0.40), B(0.66), C(1.3), D(2.4), E(3.8), F(11.0)	2.8	3.4	6.5	2.02	8.9	2.0
1"	UR3C_	A(0.40), B(0.65), C(1.3), D(2.3), E(3.5), F(10.0)	2.8	3.4	7.3	2.02	9.6	2.1
		G(8.6), H(22.3)	3.0	3.9	6.8		9.9	2.4
		J(14.9), K(4.5), M(30.8)	4.3	4.1	7.8		10.9	3.3
1 1/4"	UR3D_	B(19.4), D(4.1), E(8.7)	3.0	3.9	6.8	2.02	9.9	2.4
		C(12.7), F(34.1), G(26.8)	3.6	4.1	7.3		10.4	2.8
1 1/2"	UR3E_	A(13.4), B(4.0), C(8.3), D(32.0)	3.4	4.1	7.8	2.02	10.9	2.7
		E(23.5), F(61.1)	4.0	4.6	7.3		11.1	3.2
2"	UR3F_	A(23.9), B(56.7), C(38.2)	4.0	4.6	7.3	2.02	11.1	3.2
		D(108.5), E(82.6)	5.0	5.9	7.8		12.4	3.8
2-1/2"	UR3G_	A(38.1), B(74.1), C(99.5)	5.3	5.9	7.8	2.0	12.4	4.1
3"	UR3H_	A(75.0), B(100.0), C(125.0), D(150.0), E(175.0), F(200.0)	9.4	4.5	10.1	2.0	12.3	2.8

Inch (mm)

### PIPING CONFIGURATIONS

Our 3-Way ball allows the same 3-Way valve to be installed in either a mixing or diverting configuration without sacrificing any performance or Cv. (Valve shown is 1/2"-2-1/2". 3" valve has bypass port in Z plane.)

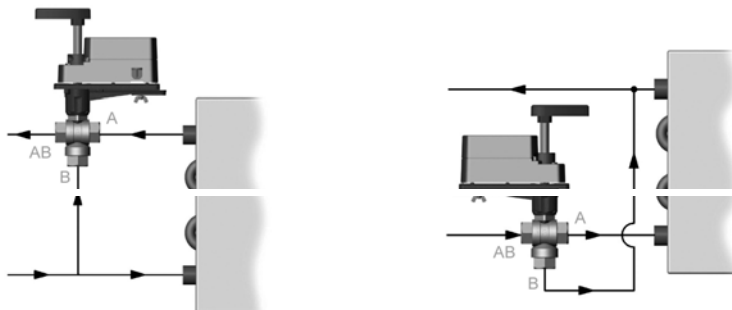

**Mixing** — fluid enters through two inlets (A, B) and exits through one outlet (AB)

**Diverting** — fluid enters through one inlet (AB) and exits through two outlets (A, B)