

VSI SERIES 1000-X

OPEN/CLOSE SERVICE ELECTRIC ACTUATORS
OPERATION AND MAINTENANCE MANUAL

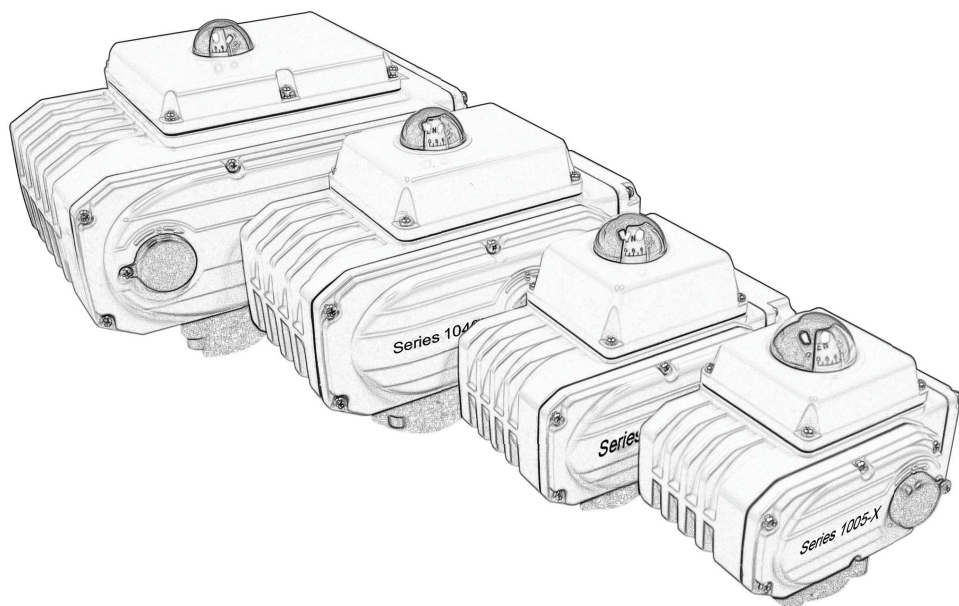

**COMMERCIAL AND INDUSTRIAL VALVES
AND AUTOMATION**

Publication DOC-00000376(D)

For information on this product and other VSI products please visit our web page - www.valvesolutions.com

CONTENTS

Safety Instructions and Warnings	2	Power Supply Requirements	8
Component Names	3	Application Requirements	9
Overall Dimensions and Specifications		Mounting on a Valve	10
1005-X	4	Adjustment of Actuator	11
1010-X	5	Operation Test	12
1020-X Thru 1060-X	6	Maintenance and Service	12
1100-X Thru 1250-X	7	Troubleshooting Guide	12
Electrical Wiring Connection	8		

SAFETY INSTRUCTIONS AND WARNINGS



WARNING

Indicates a potentially hazardous situation which, if not avoided, could result in injury or death



NOTICE

Indicates a potential situation which, if not avoided, may result in undesirable results or property damage



NOTICE

Do not manually operate the actuator without deenergizing actuator with factory installed push button or by external disconnect such as a circuit breaker.

- Actuators are equipped with an internal overheat protection device. When the motor exceeds the temperature of 257°F (125°C), the overheat protection device will automatically switch off the motor.
- Take proper leakage protection steps when installing actuator and its associated wiring, and when putting it into service. Cables connected to the actuator conduit entries must utilize proper waterproof cable ends. Tube conduit should come from below and up to the actuator to keep fluid from draining into the actuator.
- Confirm input voltages and signal polarity corresponds with those

shown for the actuator's associated data.

- Only qualified service personnel who are familiar with the installation, commissioning and operation of the actuator should perform installation and servicing.
- All actuators have the proper wiring diagram affixed to the inside of the Front Wiring Cover (#4); all wiring should follow these diagrams.
- Valve Solutions, Inc is not responsible for damages incurred because of modification, lack of proper maintenance, or improper usage of actuators



NOTICE

To prevent reduced or erratic performance a single isolated relay is required for each actuator; refer to diagram.

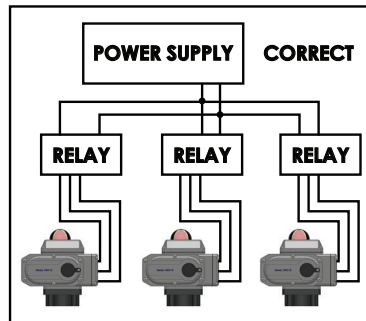
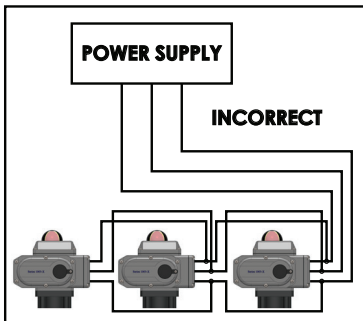

COMPONENT NAMES

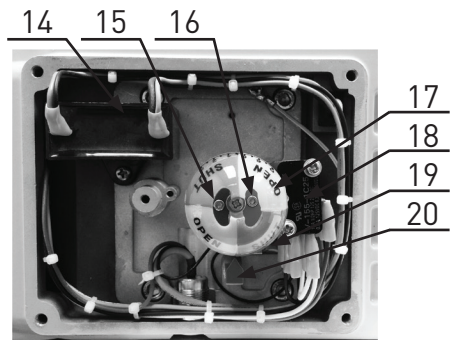
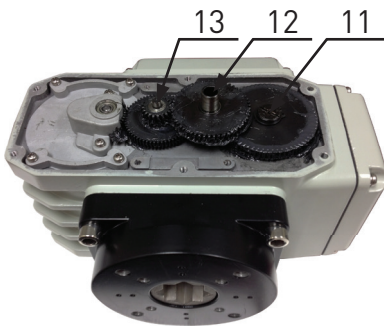
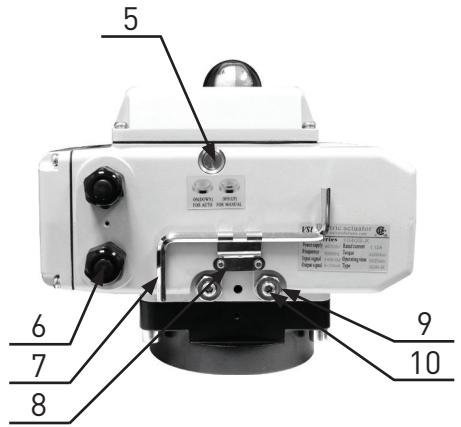
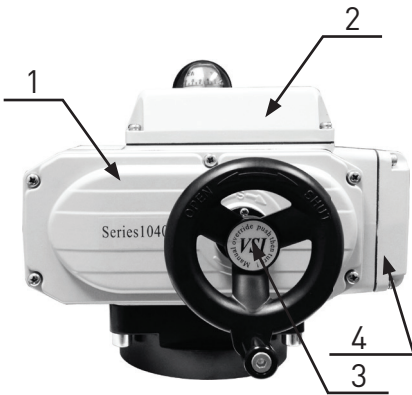

1	Side Gear Cover	11	Worm Shaft
2	Top Wiring Cover	12	Override Socket
3	Handwheel*	13	Reducing Gear Group
4	Front Wiring Cover	14	Capacitor
5	Push Button*	15	Open Cam Lock Screw
6	Conduit Plugs	16	Close Cam Lock Screw
7	Hex Handle	17	Position Indicator
8	Hex Handle Bracket	18	SPDT Limit Switches
9	Travel Stop Nut	19	Heater
10	Travel Stop Screw	20	Position Pointer

*Optional on select sizes/models

OVERALL DIMENSIONS AND SPECIFICATIONS FOR 1005-X AND 1005-XL

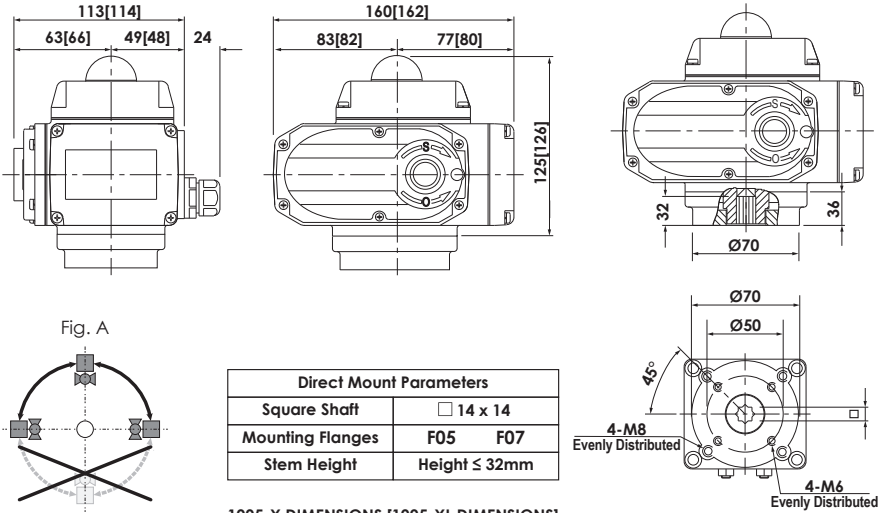

1005-X DIMENSIONS [1005-XL DIMENSIONS]
 1005/S-X DIMENSIONS [1005/S-XL DIMENSIONS]

1005-X AND 1005-XL SPECIFICATIONS			
Power Supply	24 VAC	110 VAC	220 VAC
Motor Power	10W		
Rated Current	1.7A	0.24A	0.16A
Max. Current	1.9A	0.34A	0.17A
Standard Torque	443inlb/50NM		
Run Time	1005-X: 17 ± 0.5 sec, 1005-XL: 21 ± 0.5 sec		
Turning Angle	90° Adjustable ± 5°		
Total Weight*	6.00lbs/2.72kg		
Insulating Resistance	100MΩ/250VDC	100MΩ/500VDC	
Overvoltage Withstanding	500VAC - 60 sec	1500VAC - 60 sec	
Protection Class	IP67 NEMA 4X		
Installation Angle	At or above the centerline of pipe. See Fig. A		
Ambient Temperature	-22°F to +140°F [-30°C to +60°C]		
Ambient Humidity	≤ 95% Relative Humidity		
Duty Cycle	80%		
Options	Hand-crank Override		

*Weight may vary with selected options

OVERALL DIMENSIONS AND SPECIFICATIONS FOR 1010-X

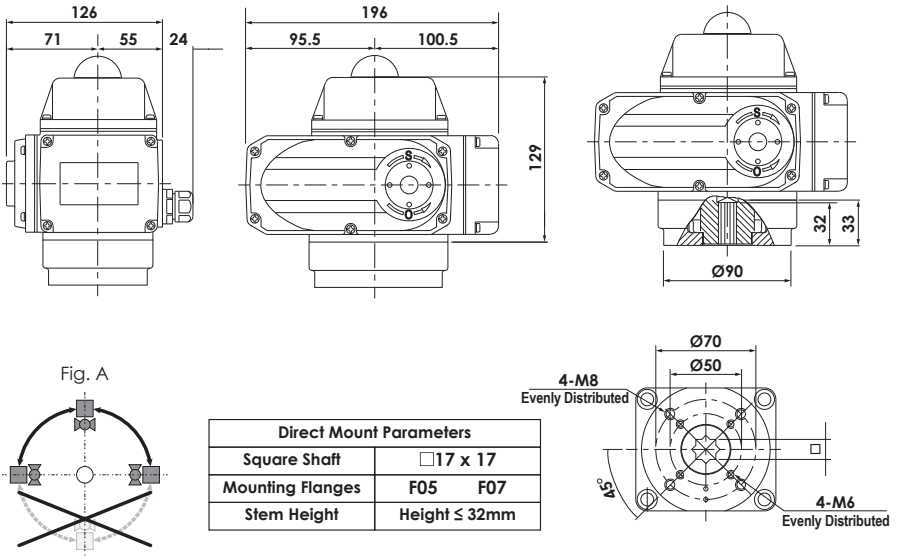

1010-X SPECIFICATIONS			
Power Supply	24 VAC	110 VAC	220 VAC
Motor Power	25W		
Rated Current	2.11A	0.57A	0.35A
Max. Current	2.40A	0.81A	0.52A
Standard Torque	885inlb/100NM		
Run Time	24.5 ± 0.5 sec		
Turning Angle	90° Adjustable ± 5°		
Total Weight*	9.10lbs/4.13kg		
Insulating Resistance	100MΩ/250VDC	100MΩ/500VDC	
Overvoltage Withstanding	500VAC - 60 sec	1500VAC - 60 sec	
Protection Class	IP67 NEMA 4X		
Installation Angle	At or above the centerline of pipe. See Fig. A		
Ambient Temperature	-22°F to +140°F (-30°C to +60°C)		
Ambient Humidity	≤ 95% Relative Humidity		
Duty Cycle	80%		
Options	Handwheel Override, Motor Pushbutton ^x		

*Weight may vary with selected options

^xNA on 24VAC Units

OVERALL DIMENSIONS AND SPECIFICATIONS FOR 1020-X THRU 1060-X

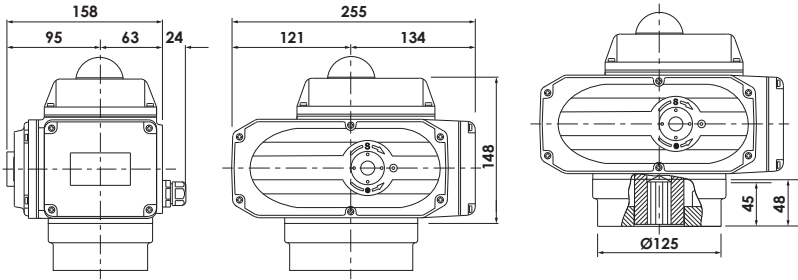
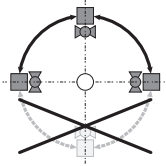
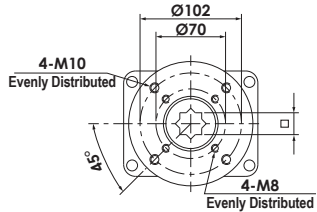

Fig. A



Direct Mount Parameters	
Square Shaft	□ 27 x 27
Mounting Flanges	F07 F10
Stem Height	Height ≤ 45mm



1020-X/1040-X/1060-X SPECIFICATIONS				
Power	Model	1020-X	1040-X	1060-X
24VAC	Motor Power	40W	40W	NA
	Rated Current	3.7A	6.8A	
	Max. Current	3.9A	7.25A	
	Total Weight*	19.9lbs/9.03kg	21.4lbs/9.71kg	
110VAC	Motor Power	40W	90W	90W
	Rated Current	0.65A	1.12A	1.18A
	Max. Current	1.68A	3.41A	3.60A
	Total Weight*	19.4lbs/8.80kg	20.9lbs/9.46kg	20.9lbs/9.463kg
220VAC	Motor Power	40W	90W	90W
	Rated Current	0.37A	0.57A	0.60A
	Max. Current	0.78A	1.78A	1.87A
	Total Weight*	19.7lbs/8.91kg	21.2lbs/9.59kg	21.1lbs/9.55kg
Standard Torque		1,770inlb/200NM	3,540inlb/400NM	5,310inlb/600NM
Run Time		28.5 ± 0.5 sec	27.5 ± 0.5 sec	34.5 ± 0.5 sec
Turning Angle		90° Adjustable ± 5°		
Insulating Resistance		24VAC: 100MΩ/250VDC 110/220VAC: 100MΩ/500VDC		
Oversoltage Withstanding		24VAC: 500VAC - 60 sec 110/220VAC: 1500VAC - 60 sec		
Protection Class		IP67 NEMA 4X		
Installation Angle		At or above the centerline of pipe. See Fig. A		
Ambient Temperature		-22°F to +140°F [-30°C to +60°C]		
Ambient Humidity		≤ 95% Relative Humidity		
Duty Cycle		80%		
Options		Handwheel Override, Motor Pushbutton ^x		

*Weight may vary with selected options
^xNA on 24VAC Units

OVERALL DIMENSIONS AND SPECIFICATIONS FOR 1100-X THRU 1250-X

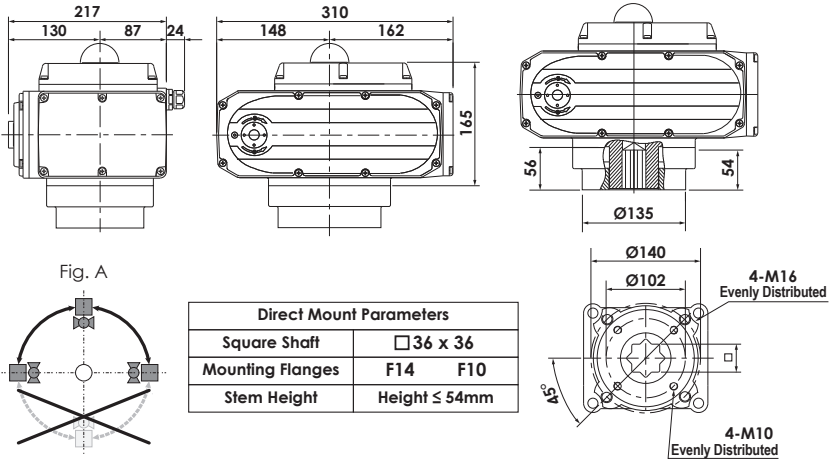

1100-X/1160-X/1250-X SPECIFICATIONS

Power	Model	1100-X	1160-X	1250-X
110VAC	Motor Power	120W	140W	140W
	Rated Current	1.75A	1.93A	1.93A
	Max. Current	3.80A	3.95A	3.95A
	Total Weight*	40.8lbs/18.5kg	41.8lbs/19.0kg	41.9lbs/19.0kg
220VAC	Motor Power	140W	140W	140W
	Rated Current	0.94A	0.98A	0.98A
	Max. Current	2.12A	2.20A	2.20A
	Total Weight*	41.2lbs/18.7kg	41.9lbs/19.0kg	42.4lbs/19.2kg
Standard Torque		8,850inlb/1,000NM	14,160inlb/1,600NM	22,125inlb/2,500NM
Run Time		26.5 ± 0.5 sec	38.5 ± 0.5 sec	63.5 ± 0.5 sec
Turning Angle		90° Adjustable ± 5°		
Insulating Resistance		100MΩ/500VDC		
Overtoltage Withstanding		1500VAC - 60 sec		
Protection Class		IP67 NEMA 4X		
Installation Angle		At or above the centerline of pipe. See Fig. A		
Ambient Temperature		-22°F to +140°F [-30°C to +60°C]		
Ambient Humidity		≤ 95% Relative Humidity		
Duty Cycle		80%		
Options		Handwheel Override, Motor Pushbutton		

*Weight may vary with selected options

ELECTRICAL WIRING CONNECTION

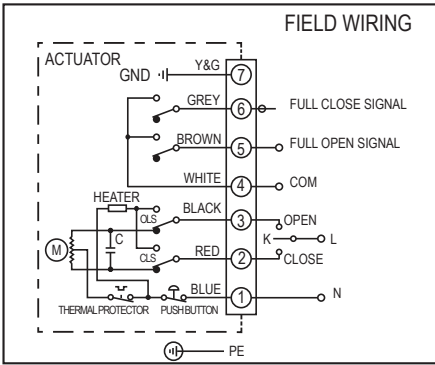

Models	Contact Ratings	
	AC Voltage	DC Voltage
1005-X and 1005-XL	3A/250VAC	NR
1010-X thru 1250-X	15A/250VAC	0.6A/125VDC

The opening and closing operation of the actuator is regulated with the travel limit switches which interrupt the power circuit to the motor. The two power legs and a common are needed in order to drive the actuator open or closed. Two SPDT switches are provided to give end of travel status indication. For all units, except the 1005-X, a manual override push button is included to isolate motor for manual hand crank or wheel operation.

TERMINAL WIRING

1. Power Common
2. Close Operation (Power Hot)
3. Open Operation (Power Hot)
4. Auxiliary Contact Common
5. Auxiliary Contact Open Status
6. Auxiliary Contact Close Status
7. Chassis Ground



WARNING

Power must be removed from actuator using manual override pushbutton, or disconnect/circuit breaker for the 1005-X, before manual operation. If manual operation is attempted with power connected actuator handwheel or crank may rotate and cause personnel injury.

POWER SUPPLY REQUIREMENTS

- Power supply for the corresponding unit must meet the electrical requirements for voltage and current ratings as show in its specifications.
- The power supply tolerance shall be as follows:

Rating	24 V	110V	220V
Range	21.6V-26.4V	99V-121V	198V-242V
Frequency	60 Hz		

Circuit Breaker Fuses

Recommended fuses for circuit breakers are as follows:

Rating	24V	110V	220V
1005-X & 1005-XL	5A	3A	2A
1010-X	7A	5A	3A
1020-X & 1040-X	10A	7A	5A
1060-X	NA	7A	5A
1100-X, 1160-X, & 1250-X		10A	7A

24VAC Transformers

Minimum recommended 120V/24V power transformer ratings are as follows:

Model	Transformer
1005-X & 1005-XL	50VA
1010-X	50VA
1020-X	150VA
1040-X	200VA

Care should be taken sizing and wiring 120V/24V transformers, considering wiring transformer primaries in series will split voltage and in parallel will split current.

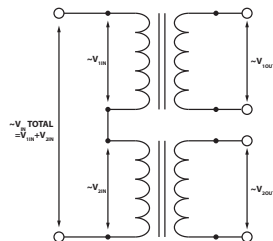

APPLICATION REQUIREMENTS

Installation Conditions

- Series 1000-X units may be installed in indoor or outdoor conditions up to IP67 or NEMA 4X



WARNING

Series 1000-X units are not rated for hazardous environments and caution should be taken to avoid flammable and explosive environments.

- Manual override operation and maintenance tasks should be taken into consideration when installing units.
- Ambient temperature should be within -22°F to +140°F.

Medium/Radiant Heat

- Care should be taken to prevent the heat of the working medium from raising the actuator above its rated ambient temperature limits.
- When the temperature of the working medium exceeds the actuator's rated temperature limits, a thermal coupling shall be installed to reduce heat transfer between the medium and the actuator.



WARNING

Medium temperatures above 175°F require the use of bracket and thermal isolating coupling in lieu of direct mounting to valve.

Conduit and Cable Installation

- Refer to Figure 1.1 and 1.2 when connecting conduit to Series 1000-X actuators.
- Conduit entries are 1/2" NPT. All entry fittings should be sealed watertight.
- Best practice when connecting conduit to Series 1000-X actuators is to run the conduit from below the actuator upward to prevent condensation from conduit working into the actuator; as shown in Figure 1.2.

Conduit and Cable Installation (Cont.)

- If actuator must be installed below conduit, a drip loop or drain should be provided to allow any water to exit the piping.

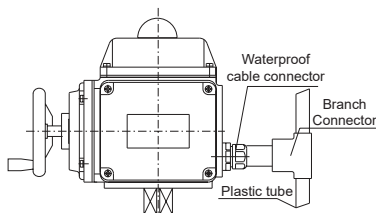

Figure 1.1

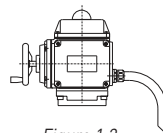
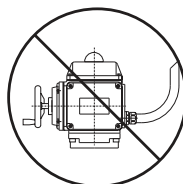

Figure 1.2

- Refer to Figure 2 for installation of cable directly into unit without the use of conduit.
- The outer diameter of the cable shall be $\varnothing 9\text{mm} - \varnothing 11\text{mm}$.
- Use of cable smaller than specified may allow water to enter the unit and damage the electronics.
- When possible, power wiring and signal wiring should be routed through separate conduit entries; all units have two conduit entries.

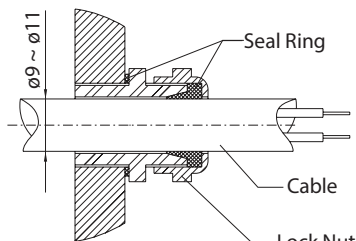

Figure 2

MOUNTING ON A VALVE

Installation of Actuator to Valve

- NOTE: Direct mounting the actuator removes the bracket and coupling from the mounting process, but the remainder of the process remains the same.
- Rotate valve to fully closed position. Ensure that the valve rotates freely with no obstruction.
- Using the proper bolts attach the bracket to the valve – tighten only loosely.
- Apply grease or anti-seize to the valve shaft and place the coupling onto the valve stem.
- Using the manual override handle or handwheel, rotate the actuator to the fully closed position so that the position indicator displays "SHUT".
- Apply grease or anti-seize to the coupling at the actuator interface.
- Place the actuator onto the bracket, aligning the coupling drive and actuator.
- Attach the bracket with proper bolts and tighten all bolts. If bolt holes are not aligned, but within

5° alignment, rotate actuator handwheel to move actuator into alignment.

- Drive the actuator using the manual crank or handwheel and confirm that the valve rotates without obstruction. Ensure the valve is fully open as the actuator rotates to the full open position

Mounting Tips

- If using your own bracket or one provided by third party supplier, ensure that the materials provided are manufactured professionally and meet the requirements of Figure 3.
- The coupling valve and actuator drive ends must be absolutely coaxial to prevent damage to actuator.
- Poor locating of bolt holes in the bracket may cause improper indexing of the valve and actuator, preventing the actuator from fully opening or closing the valve.
- Only tighten bolts after the actuator, bracket, and valve have been properly aligned.

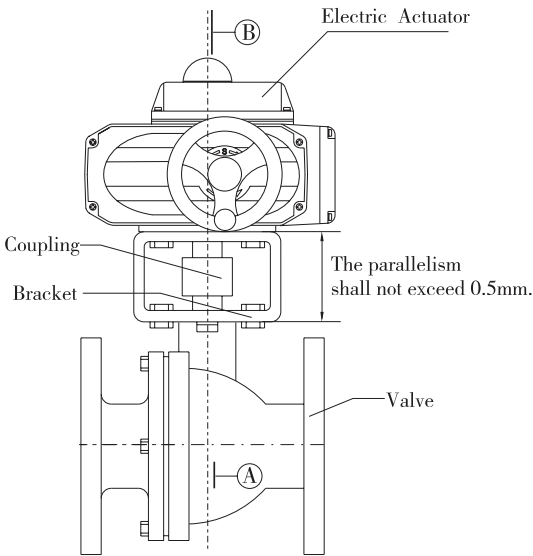

The coaxiality between axes **A** and **B** shall not exceed $\phi 0.2\text{mm}$.

Figure 3

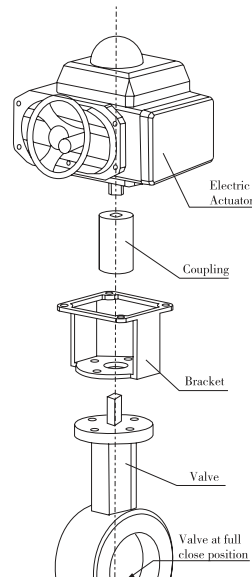
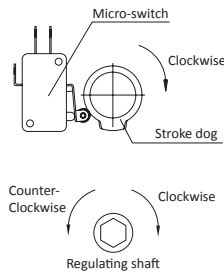
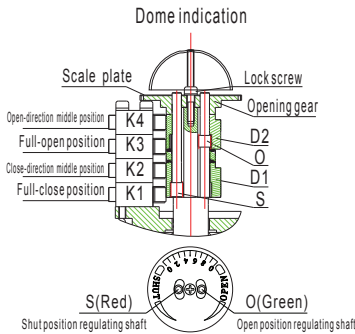

Figure 4

ADJUSTMENT OF ACTUATOR

Switch Adjustment

- Using the manual handwheel or hand crank, drive the valve to the fully closed position. Visually inspect the valve disc/ball to ensure it is fully closed, but not over-rotated close.
- If the dome indicator does not indicate fully close remove the top wiring cover using a screwdriver. Loosen the center Phillips head screw holding the dome indicator and rotate the indicator to the correct position. Re-tighten the screw to secure the dome indicator.
- Using a multi-meter or test indicator light test continuity between the closed limit switch contacts, 4 and 6 on the terminal block. If electric test equipment is not available, listen for the audible click of the limit switches.
- If the contacts indicate continuity (switch activated):
 - Using a 2mm Allen wrench, rotate the closed position regulating shaft (S) in the counterclockwise direction until the switch deactivates.
 - Then rotate the close regulating shaft clockwise until the switch reactivates.
- If the contacts do not indicate continuity (switch deactivated)
 - Using a 2mm Allen wrench, rotate the closed position regulating shaft (S) in the clockwise direction until the switch activates.
- Repeat steps 1-5 for the open position, testing for continuity between terminals 4 and 5 on the terminal block and using the open position regulating shaft (O).



MECHANICAL ADJUSTMENT



WARNING

limit switches are provided to set travel limits. Please refer to section above to set travel limit.

To prevent damage, the mechanical stops should never be used to limit the rotation of the actuator. Electrical

- Using the manual override handle or handwheel, rotate the valve in the closed direction until the feedback indicates a current or voltage that correlates with fully closed as established in the controller adjustment section. Rotate handwheel or crank in close direction an additional 1/2 turn.
- Loosen the lock-nut on the left side of the unit and rotate the adjusting screw clockwise using an Allen wrench until the screw comes into contact with the stopper, then back off 1/2 turn counterclockwise. Tighten lock nut to finish close mechanical stop adjustment.
- Repeat steps 1-2 for the open direction.

Actuator Size	Lock Nut	Adjusting Screw
1005-X & 1005-XL	10mm	3mm
1010-X	13mm	4mm
1020-X to 1060-X	17mm	5mm
1100-X to 1250-X	19mm	6mm

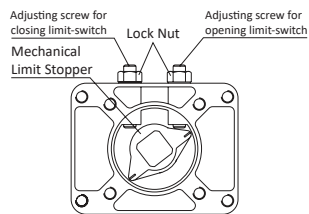

Figure 6

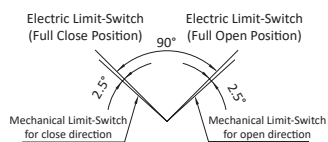

Figure 7

OPERATION TEST

1. Connect wiring per the wiring diagram – located in the front wiring cover.
2. Verify that the valve rotates to the closed position by observing the dome indicator points to the red zero “shut”.
3. Verify that the valve rotates to the open position by observing the dome indicator points to the yellow zero “open”.
4. After all adjustments mentioned above, check the alignment of the dome indicator scale and pointer. If the pointer is not aligned properly on open and closed position adjust as needed by loosening the dome lock screw and re-tightening.

MAINTENANCE AND SERVICE

- All actuators utilize high grade molybdenum based grease for their gears. No lubrication or periodic maintenance is required.
- If actuators are rarely cycled, periodic rotation operation should be scheduled to check if abnormal conditions are present.

TROUBLESHOOTING GUIDE

PROBLEM	CAUSE	REMEDY
Actuator fails to operate	Power is not connected	Connect power or replace circuit breaker
	Manual/Auto pushbutton is not engaged	Press manual/auto pushbutton on unit to engage power
	Voltage is too low	Check and correct voltage
	The actuator is in thermal protection mode due to over torque situation, or ambient temperature is too high	Remove over torque conditions. Check valve to ensure manual movement without sticking. Cool down ambient temperature. Ensure that mechanical limits are not keeping actuator from reaching electrical limits.
	Defective micro-switch	Replace micro-switch or Contact VSI
	Defective capacitor	Contact VSI
Actuator does not feedback for open/closed position	Defective micro-switch	Replace micro-switch or Contact VSI
	Improper micro-switch position	Readjust the electrical limits according to instructions
Motor continues to operate after reaching limit	Defective micro-switch	Replace micro-switch or Contact VSI
	Power is not connected correctly	Recheck power connections
	Improper micro-switch position	Readjust the electrical limits according to instructions
	Mechanical limit is out of adjustment	Readjust the mechanical limits according to instructions
Water present inside of actuator	Inlet power cables are not properly installed per instructions	Recheck conduit connections
	The dome indicator lens is broken	Contact VSI
	Housing screws are not tightened and sealed	Tighten housing screws
	Condensation heater not working or not connected	Check heater connections or Contact VSI



Valve Solutions Inc, LLC
 tel: (770) 740 0800
 fax: (770) 740 8777
www.valvesolutions.com