

M9220-xxx-3 Electric Spring Return Actuators

Description

The M9220-xxx-3 Actuators are direct mount, spring return electric actuators that operate with these available power options:

- AC 24 V at 50/60 Hz or DC 24 V (AGx, BGx, GGx, HGx)
- AC 120 V at 60 Hz (BAx)
- AC 230 V at 50/60 Hz (BDx)

These bidirectional actuators do not require a damper linkage, and are easily installed on dampers with 1/2 to 3/4 in. or 12 to 19 mm round shafts, or 3/8 and 1/2 in. or 10, 12, and 14 mm square shafts using the standard shaft clamp included with the actuator. An optional M9220-600 Jackshaft Coupler Kit is available for 3/4 to 1-1/16 in. or 19 to 27 mm round shafts, or 5/8 and 3/4 in. or 16, 18, and 19 mm square shafts.

A single M9220-xxx-3 Electric Spring Return Actuator provides a running and spring return torque of 177 lb-in (20 N-m). Two or three models mounted in tandem deliver twice or triple the torque. Integral line voltage auxiliary switches are available on the xxC models to indicate end-stop position, or to perform switching functions within the selected rotation range.

Refer to the *M9220-xxx-3 Electric Spring Return Actuators Product Bulletin (LIT-12011057)* for important product application information.

Features

- available torques of 177 lb-in (20 N-m) for single actuators, 354 lb-in (40 N-m) for two models, and 531 lb-in (60 N-m) for three models mounted in tandem — offer a selection that is most suitable for the application
- reversible mounting design — simplifies installation and enables the actuator to spring return in either direction
- electronic stall detection throughout entire rotation range — extends the life of the actuator by deactivating the actuator motor when an overload condition is detected
- removable coupler — adapts to a shorter damper shaft
- integral 48 in. (1.2 m) halogen-free cables with colored and numbered conductors — simplify field wiring
- integral auxiliary switches (xxC Models) — provide one fixed and one adjustable switch point with line voltage capability
- NEMA 2 (IP54) rated aluminum enclosure — protects the internal components of the actuator from dirt and moisture
- easy-to-use locking manual override with auto release and crank storage — allows for manual positioning of the actuator hub
- integral connectors for 3/8 in. flexible metal conduit — simplify installation and field wiring

Applications

The M9220-xxx-3 Electric Spring Return Actuators provide reliable control of dampers and valves in Heating, Ventilating, and Air Conditioning (HVAC) systems. The M9220-xxx-3 Actuators are available for use with on/off, floating, and proportional controllers.



M9220-xxx-3 Electric Spring Return Actuator

Repair Information

If the M9220-xxx-3 Electric Spring Return Actuators fails to operate within its specifications, refer to the *M9220-xxx-3 Electric Spring Return Actuators Product Bulletin (LIT-12011057)* for a list of repair parts available.

Selection Chart

Code Number	Control Type	Auxiliary Switches	Power Requirements
M9220-AGA-3	Floating	None	AC 24 V at 50/60 Hz or DC 24 V
M9220-AGC-3	Floating	Two	AC 24 V at 50/60 Hz or DC 24 V
M9220-BAA-3	On/Off	None	AC 120 V at 60 Hz
M9220-BAC-3	On/Off	Two	AC 120 V at 60 Hz
M9220-BDA-3	On/Off	None	AC 230 V at 50/60 Hz
M9220-BDC-3	On/Off	Two	AC 230 V at 50/60 Hz
M9220-BGA-3	On/Off	None	AC 24 V at 50/60 Hz or DC 24 V
M9220-BGC-3	On/Off	Two	AC 24 V at 50/60 Hz or DC 24 V
M9220-GGA-3	Proportional	None	AC 24 V at 50/60 Hz or DC 24 V
M9220-GGC-3	Proportional	Two	AC 24 V at 50/60 Hz or DC 24 V
M9220-HGA-3	Proportional w/Adjustable Zero and Span	None	AC 24 V at 50/60 Hz or DC 24 V
M9220-HGC-3	Proportional w/Adjustable Zero and Span	Two	AC 24 V at 50/60 Hz or DC 24 V

M9220-xxx-3 Electric Spring Return Actuators (Continued)

Accessories

Code Number	Description
DMPR-KC003 ¹	7 in. (178 mm) Blade Pin Extension (without Bracket) for Johnson Controls® Direct-Mount Damper Applications
M9000-158	Tandem Mounting Kit used to Mount Two Models of M9220-xxx-3 Proportional Electric Spring Return Actuators
M9000-153	Crank arm
M9000-170	Remote Mounting Kit, Horizontal. Kit includes Mounting Bracket, M9000-153 Crank Arm, Ball Joint, and Mounting Bolts
M9000-171	Remote Mounting Kit, Vertical. Kit includes Mounting Bracket, M9000-153 Crank Arm, Ball Joint, and Mounting Bolts
M9000-200	Commissioning Tool that Provides a Control Signal to Drive 24 V On/Off, Floating, Proportional, and/or Resistive Electric Actuators
M9000-320	Weather Shield Enclosure - NEMA 3R enclosure for protecting a single M9210/20 actuator from rain, sleet, or snow
M9000-604	Replacement Anti-rotation Bracket Kit (with Screws) for M9220-xxx-3 Proportional Electric Spring Return Actuators
M9220-600	1 in. (25 mm) Jackshaft Coupler Kit (with Locking Clip) for Mounting M9220-xxx-3 Proportional Electric Spring Return Actuators on Dampers with 3/4 to 1-1/16 in. or 19 to 27 mm Round Shafts, or 5/8 and 3/4 in. or 16, 18, and 19 mm Square Shafts
M9220-601	Replacement Coupler Kit (with Locking Clip) for Mounting M9220-xxx-3 Proportional Electric Spring Return Actuators on Dampers with 1/2 to 3/4 in. or 12 to 19 mm Round Shafts, or 3/8 and 1/2 in. or 10, 12, and 14 mm Square Shafts
M9220-602	Replacement Locking Clips for M9220-xxx-3 Proportional Electric Spring Return Actuators (Five per Bag)
M9220-603	Adjustable Stop Kit for M9220-xxx-3 Proportional Electric Spring Return Actuators
M9220-604	Replacement Manual Override Cranks for M9220-xxx-3 Proportional Electric Spring Return Actuators (Five per Bag)
M9220-610	Replacement Shaft Gripper, 10 mm Square Shaft with Locking Clip
M9220-612	Replacement Shaft Gripper, 12 mm Square Shaft with Locking Clip
M9220-614	Replacement Shaft Gripper, 14 mm Square Shaft with Locking Clip

1. Furnished with the damper and may be ordered separately.

M9220-xxx-3 Electric Spring Return Actuators (Continued)

Dimensions

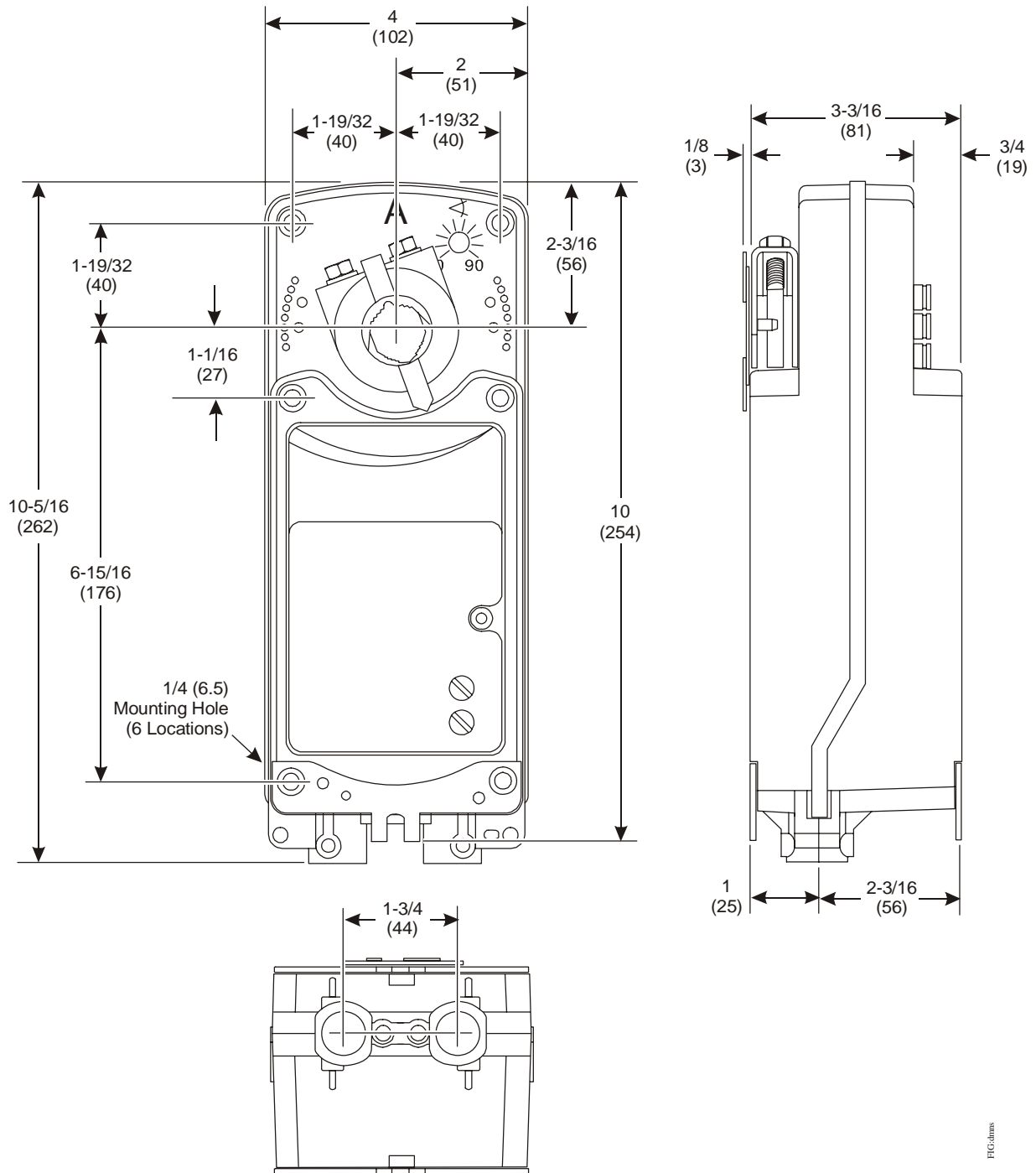

M9220-xxx-3 Electric Spring Return Actuator Dimensions, in. (mm)

FIG. 3/ans

M9220-xxx-3 Electric Spring Return Actuators (Continued)

Technical Specifications

M9220-xxx Electric Spring Return Actuators (Part 1 of 2)		
Product Codes		M9220-AGx-3 Models: Floating M9220-Bxx-3 Models: On/Off M9220-GGx-3 Models: Proportional M9220-HGx-3 Models: Proportional Adjustable
Power Requirements	AGx, HGx, GGx Models	AC 24 V (19.2 to 30 V) at 50/60 Hz: Class 2, 15.5 VA Running, 7.7 VA Holding Position; DC 24 V (21.6 to 26.4 V): Class 2, 6.7 W Running, 2.9 W Holding Position
	BAx Models	AC 120 V (AC 102 to 132 V) at 60 Hz: 0.25 A Running, 0.13 A Holding Position
	BDx Models	AC 230 V (AC 198 to 264 V) at 50/60 Hz: 0.15 A Running, 0.09 A Holding Position
	BGx Models	AC 24 V (19.2 to 30 V) at 50/60 Hz: Class 2, 24.6 VA Running, 7.7 VA Holding Position; DC 24 V (21.6 to 26.4 V): Class 2, 17.6 W Running, 2.8 W Holding Position
Transformer Sizing Requirements	AGx, HGx, GGx Models	20 VA Minimum per Actuator
	Bxx Models	25 VA Minimum per Actuator
Input Signal/Adjustments	AGx Models	DC 0 (2) to 10 V or 0 (4) to 20 mA with Field Furnished 500 ohm resistor; Switch Selectable Direct or Reverse Action with Signal Increase, 500 ms minimum pulse width
	GGx Models	Factory Set DC 0 to 10 V, CW Rotation with Signal Increase; Selectable DC 0 (2) to 10 V or 0 (4) to 20 mA with Field Furnished 500 ohm, 0.25 W minimum resistor; Switch Selectable Direct or Reverse Action with Signal Increase
	HGx Models	Factory Set DC 0 to 10 V, CW Rotation with Signal Increase; Selectable DC 0 to 10 V or 0 to 20 mA with Field Furnished 500 ohm, 0.25 W minimum resistor; Start Point Programmable DC 0 to 10 V; Span Programmable DC 2 to 10 V; Switch Selectable Direct or Reverse Action with Signal Increase
Control Input Impedance	GGx, HGx Models	Voltage Input: 200,000 ohms; Current Input: 500 ohms with Field Furnished 500 ohm Resistor
Feedback Signal	GGx Models	0 (2) to 10 VDC for Desired Rotation Range up to 90°; Corresponds to Rotation Limits, 500 mA maximum
	HGx Models	0 to 10 VDC for Desired Rotation Range up to 90°; Corresponds to Rotation Limits, 500 mA maximum
Auxiliary Switch Rating	xxC Models	Two Single-Pole, Double-Throw (SPDT), Double-Insulated Switches with Gold Flash Contacts: AC 24 V, 50 VA Pilot Duty; AC 120 V, 5.8 A Resistive, 1/4 hp, 275 VA Pilot Duty; AC 240 V, 5.0 A Resistive, 1/4 hp, 275 VA Pilot Duty
Spring Return		Direction is Selectable with Mounting Position of Actuator: Side A, Actuator Face Away from Damper for CCW Spring Return; Side B, Actuator Face Away from Damper for CW Spring Return
Running and Spring Return Torque		177 lb-in (20 N-m) for a Single Actuator; 354 lb-in (40 N-m) for Two Models Mounted in Tandem 531 lb-in (60 N-m) for Three Models Mounted in Tandem
Valid Tandem Combinations		Two M9220-Bxx-3 Three M9220-AGx-3 One M9220-HGx-3 master with one or two M9220-GGx-3 slaves One M9220-GGx-3 master with one or two M9220-GGx-3 slaves
Rotation Range		Adjustable from 30 to 90° CW or CCW with Optional M9220-603 Adjustable Stop Kit; Mechanically Limited to 90°
Rotation Time Power On (Running)	AGx, HGx, GGx Models	150 Seconds for 0 to 177 lb-in (0 to 20 N-m) at All Operating Conditions; Independent of Load
	BGx Models	24 to 57 Seconds for 0 to 177 lb-in (0 to 20 N-m) at All Operating Conditions; 35 Seconds Nominal at Full Rated Load
Rotation Time Power Off (Spring Returning)	AGx, HGx, GGx Models	20 Seconds for 0 to 177 lb-in (0 to 20 N-m) at Room Temperature
	BGx Models	11 to 15 Seconds for 0 to 177 lb-in (0 to 20 N-m) at Room Temperature; 35 Seconds Maximum for 0 to 177 lb-in (0 to 20 N-m) at -22°F (-30°C) 130 Seconds Maximum for 0 to 177 lb-in (0 to 20 N-m) at -40°F (-40°C)
Cycles		60,000 Full Stroke Cycles; 1,500,000 repositions
Audible Noise Rating (AGx, HGx, GGx Models)	Power On (Running)	<40 dBA at 39-13/32 in. (1 m)
	Power On (Holding)	<20 dBA at 39-13/32 in. (1 m)
	Power Off (Spring Returning)	<55 dBA at 39-13/32 in. (1 m)

M9220-xxx-3 Electric Spring Return Actuators (Continued)

M9220-xxx Electric Spring Return Actuators (Part 2 of 2)		
Audible Noise Rating (BGx Models)	Power On (Running)	<66 dBA at 39-13/32 in. (1 m)
	Power On (Holding)	<18 dBA at 39-13/32 in. (1 m)
	Power Off (Spring Returning)	<66 dBA at 39-13/32 in. (1 m)
Electrical Connections	Actuator (All Models)	48 in. (1.2 m) Halogen-Free Cable with 18 AWG (0.75 mm ²) Wire Leads
	Auxiliary Switches (xxC Models)	48 in. (1.2 m) Halogen-Free Cable with 18 AWG (0.75 mm ²) Wire Leads
Conduit Connections		Integral Connectors for 3/8 in. (10 mm) Flexible Metal Conduit
Mechanical Connections	Standard Shaft Clamp Included with Actuator	1/2 to 3/4 in. or 12 to 19 mm Diameter Round Shafts, or 3/8 and 1/2 in. or 10, 12, and 14 mm Square Shafts
	Optional M9220-600 Jackshaft Coupler Kit	3/4 to 1-1/16 in. or 19 to 27 mm Diameter Round Shafts, or 5/8 and 3/4 in. or 16, 18, and 19 mm Square Shafts
Aluminum Enclosure		NEMA 2 (IP54) for All Mounting Orientations
Ambient Conditions	Operating	-40 to 131°F (-40 to 55°C); 90% RH Maximum, Noncondensing
	Storage	-85 to 185°F (-65 to 85°C); 95% RH Maximum, Noncondensing
Dimensions		See <i>Dimensions</i> .
Compliance	North America	UL Listed, File E27734, CCN XAPX (United States) and XAPX7 (Canada)
	Europe	CE Mark, EMC Directive 89/336/EEC (M9220-xGA-3 Models)
		CE Mark, Low Voltage Directive 73/23/EEC (M9220-BDA-3 and M9220-xxC-3 Models)
Australia and New Zealand	C-Tick Mark, Australia/NZ Emissions Compliant (M9220-xGx-3 and M9220-BDx Models)	
Shipping Weight	xGx Models	6.4 lb (2.9 kg)
	BAx and BDx Models	7.6 lb (3.5 kg)