

## OpenAir™ Electric Damper Actuators

### GDE/GLB Series

### Non-spring Return Rotary

### 24 Vac - Modulating Control 0 to 10 Vdc



**Description** The OpenAir direct coupled 24 Vac non-spring return rotary electric actuators are designed for modulating control of dampers.

- Features**
- Compact, lightweight design
  - Self-adapting capability for maximum flexibility in damper positioning
  - Manual override
  - Offset and slope adjustment models available
  - Independently adjustable dual auxiliary switches available
  - cUL and UL listed; CE certified

**Application** These actuators are used in constant or variable air volume installations for control of HVAC dampers requiring up to 44 lb-in (5 Nm) or 88 lb-in (10 Nm) of torque.

### Product Numbers

**Table 1. 24 Vac Operating Voltage**

Torque	Cabling	Standard	Slope/Offset Adjustable	Dual Auxiliary Switches and Slope/Offset Adjustable	Dual Auxiliary Switches Only
44 lb-in (5 Nm)	Plenum	GDE161.1P	GDE163.1P	GDE164.1P	GDE166.1P
		GDE161.1P/B (24 pk)			
	Terminal Strip	GDE161.1T	—	—	—
		GDE161.1T/B (24 pk)	—	—	—
88 lb-in (10 Nm)	Plenum	GLB161.1P	GLB163.1P	GLB164.1P	GLB166.1P

<b>Specifications</b>	Operating voltage (G–G0)	24 Vac +20%, -15%
	Frequency	50/60 Hz
<b>Power Supply</b>	Power consumption	3.3 VA
	Input signal (Y-G0)	
<b>Control signal</b>	Voltage-input	0 to 10 Vdc
	Input resistance	100K ohms
<b>Feedback signal</b>	Position output signal (U–G0)	
	Voltage-output	0 to 10 Vdc
	Maximum output current	DC 1 mA
<b>Equipment rating</b>	Rating:	Class 2 according to UL, CSA Class III per EN60730
<b>Auxiliary features</b>	<b>Control signal adjustment</b>	
	Offset (start point)	Between 0 to 5 Vdc
	Slope (span)	Between 2 and 30 Vdc
	Dual auxiliary switch contact rating	4A resistive, 2A inductive
	Voltage	24 Vac/24 Vdc
	DC rating	12 to 30 Vdc
	DC 2A	
	Switch Range	
	Switch A	0 to 90° with 5° intervals
	Recommended range usage	0 to 45°
	Factory setting	5°
	Switch B	0 to 90° with 5° intervals
	Recommended range usage	45 to 90°
	Factory setting	85°
	Switching hysteresis:	2°
<b>Function</b>	Torque	
	GDE	44 lb-in (5 Nm)
	GLB	88 lb-in (10 Nm)
	Runtime for 90° opening or closing	
	GDE	90 sec. at 60 Hz (108 sec. at 50 Hz)
	GLB	125 sec. at 60 Hz (150 sec. at 50 Hz)
	Nominal angle of rotation	90°
Maximum angular rotation	95°	
<b>Mounting</b>	Shaft size: Minimum shaft length 3/4-inch (20 mm)	

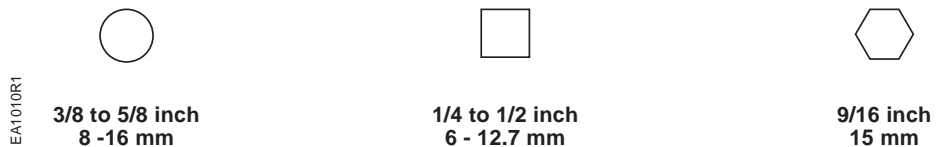

**Figure 1. Acceptable Shaft Sizes.**

<b>Specifications, continued</b>	Enclosure:	NEMA Type 2 IP54 according to EN60529
<b>Housing</b>	Material:	Durable plastic
	Gear lubrication:	Silicone-free
<b>Ambient conditions</b>	Ambient temperature	
	Operation:	-25°F to 130°F (-32°C to 55°C)
	Storage and transport:	-40°F to 158°F (-40°C to 70°C)
	Ambient humidity (non-condensing):	95% rh
<b>Agency certification</b>		UL listed to UL873 cUL certified to Canadian C22.2 No. 24-93
<b>CE conformity</b>	Standard	In accordance with the directive set forth by the European Union for Electromagnetic Compatibility (EMC): 89/336/EEC
	Emissions standards:	EN 50081-1
	Immunity standards:	EN 50082-2
<b>Miscellaneous</b>	Pre-cabled connection:	18 AWG
	Cable length:	3 feet (0.9m)
	Life cycle:	Designed for over 60,000 full strokes and a minimum of 1.5 million repositions at rated torque and temperature
	Dimensions:	See Figure 22
	Weight:	.06 lb (0.48 kg)

---

## Accessories

**NOTE:** The auxiliary switches cannot be added in the field. Order the product number that includes this option. See Table 1.

---

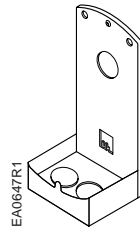

**Figure 2. Conduit adapter**

**ASK76.1U** Provides connection between the actuator and conduit.

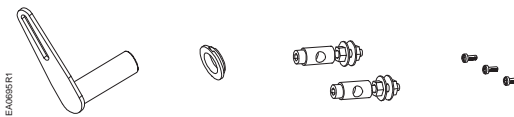

**Figure 3. Rotary to linear**

**ASK71.5** Allows a direct-coupled actuator to provide an auxiliary linear drive.

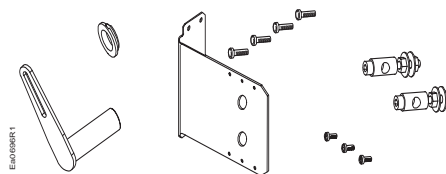

**Figure 4. Rotary to linear with bracket**

**ASK71.6** Allows economical mounting of an OpenAir actuator to a variety of surfaces.

Should be used in applications where the actuator can be rigid-surface mounted and a linear stroke output is needed.

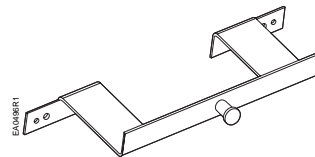

**Figure 5. Tandem Mount Bracket.**

**ASK73.1** Bracket provides extended anti-rotation pin allowing two OpenAir actuators to directly drive a single damper shaft. For use with two- and three-position actuators.

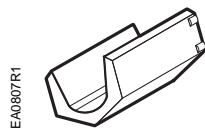

**Figure 6. Shaft insert**

**ASK78.3U** Shaft insert for use with 3/8-inch (8 to 10 mm) diameter shafts. (10/pk). Included in box with GDE/GLB series.

**NOTE:** Factory-installed 1/2-inch guide must be removed prior to installation.

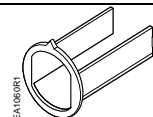

**Figure 7. 1/2-inch Shaft Guide**

**985-101P25:** Shaft guide, 1/2-inch (25/pk). Factory installed with GDE/GLB Series.

### Actuator Components

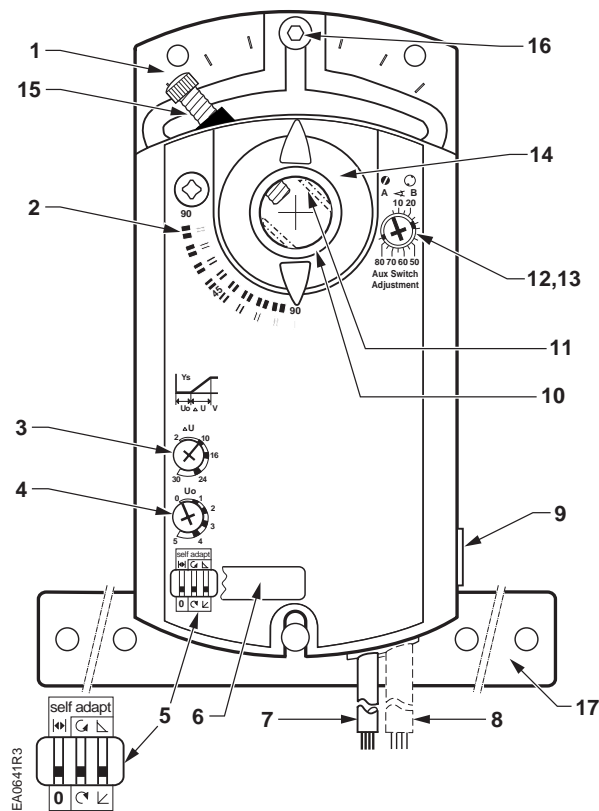

### Legend

1. Base plate
2. Positioning scale for angle of rotation
3. Slope adjustment
4. Offset (start point) adjustment
5. DIP switches
6. Cover for DIP switches
7. Connection cables
8. Connection cables
9. Manual override
10. Coupling bushing
11. Factory installed 1/2-inch guide
12. Auxiliary switch A
13. Auxiliary switch B
14. Position indicator
15. Adjustment lever with locking screw (4 mm hex)
16. Set screw for mechanical range stop (4 mm hex)
17. Mounting bracket

**Figure 8. Parts of the Actuator.**

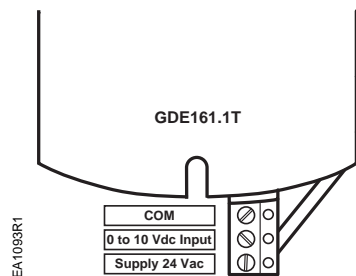

**Figure 9. Special Features of Terminal Strip Model.**

### GDE161.1T

This model uses a terminal strip for connection purposes rather than cable connections (7,8)

**Operation**

A continuous 0 to 10 Vdc signal from a controller to wire 8 (Y) operates the damper actuator. The angle of rotation is proportional to the control signal. A 0 to 10 Vdc position feedback output signal is available between wire 9 (U) and wire 2 (G0) to monitor the position of the damper motor.

In the event of a power failure, the actuator holds its position. In the event that only the control signal is lost, the actuator returns to the "0" position.

**Life expectancy**

An improperly tuned loop will cause excessive repositioning that will shorten the life of the actuator.

**Control signal adjustment**

**GDE/GLB163.1P and GDE/GLB164.1P:** For sequencing and the electronic limitation of the angle of rotation.

Use the  $U_o$  potentiometer to set the offset (start point) between 0 to 5 Vdc.  
 Use the  $\Delta U$  potentiometer to set the slope (span) between 2 to 30 Vdc.

**NOTE:** The Y input is limited to a maximum of 10 Vdc. If the sum of the offset and slope setting is greater than 10V, the angle of rotation is reduced providing the feature of electronic limitation of the angle of rotation.

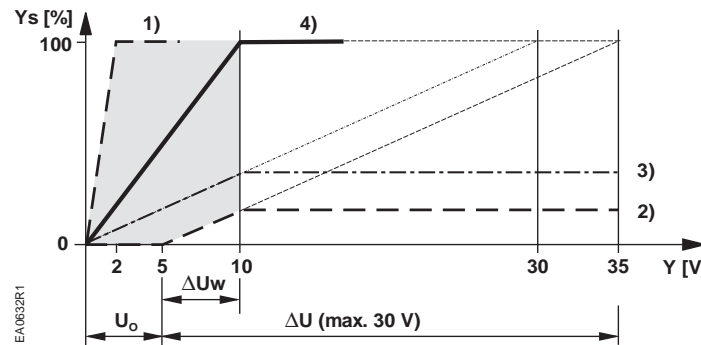

**Figure 10.**

- $Y_s$  Actuator position (100% = angle of rotation  $90^{\circ}$ \*)
- $Y$  Control input signal
- $U_o$  Offset (start point)
- $\Delta U$  Slope
- $\Delta U_w$  Active voltage range ( $Y_s$  changes)

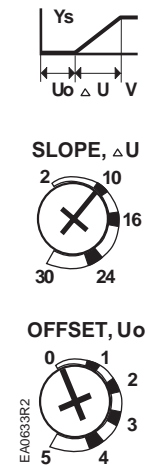

Setting for  
 10V slope  
 0 Vdc offset

**Figure 11.**

\* When the mechanical limitation of the angle of rotation and self-adapt function are ON, 100% does not equal  $90^{\circ}$ .

**Table 2.**

Examples in Figure 3	$U_o$ Offset Vdc	$\Delta U$ Slope Vdc	Active Voltage Range Vdc	$Y_s$ Actuator Position
1. Minimum slope	0	2	0 to 2	0 to 100%
2. Limitation of rotation	5	30	5 to 10	0 to 16.7%
3. Limitation of rotation	0	30	0 to 10	0 to 33.3%
4. Setting shown in Figure 4	0	10	0 to 10	0 to 100%

**Operation,  
 continued**

Determine the setting needed to electronically limit the angle of rotation between 0 to 50% (0 to 45°) using a 2 to 10 Vdc input.

**Control signal  
 adjustment example:**

Calculating the value of  $\Delta U$ :

$$\Delta U = \frac{100[\%]}{\text{working angle of rotation } Y_s [\%]} \times (10[Vdc] - U_o[Vdc]) = \frac{100\%}{50\%} \times (10Vdc - 2Vdc) = 16Vdc$$

Settings:  $U_o = 2 Vdc$ ;  
 $\Delta U = 16 Vdc$

Electronic limitation angle of rotation  $Y_s = 50\%$  (45°)  
 Slope  $\Delta U = 16V$   
 Active voltage range  $\Delta U_w = 2 \text{ to } 10 Vdc$

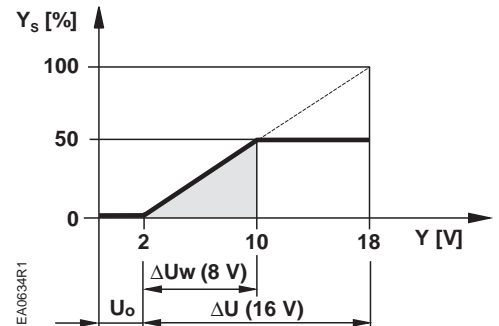

**Figure 12. Example.**

**Auxiliary switches**

GDE/GLB164.1P and GDE/GLB166.1P

Figure 13 shows the adjustable switching values for the auxiliary switches A and B.

Actuator Scale:  
 clockwise  
 Adjustment range for  
 Switches A and B  
 Setting interval: 5°  
 Switching hysteresis: 2°  
 Actuator Scale:  
 counterclockwise

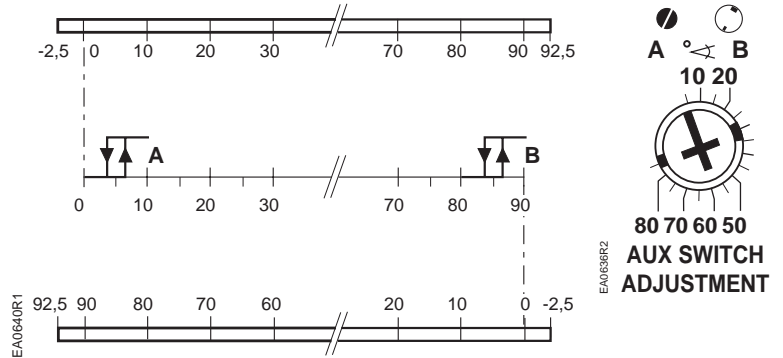

**Figure 13. Adjustable Switching Values for the Dual Auxiliary Switches.**

**NOTE:** The auxiliary switch setting shafts rotate with the actuator. The scale is valid only when the actuator is in the "0" position on clockwise motion.

Use the long arm of the X to point to the position of switch A. Use the narrower tab on the red ring to point to the position of switch B.

### Dual in-line package (DIP) switches

Raise the protective cover from left to right to locate the DIP switches. See Figure 2 for the location of the cover.

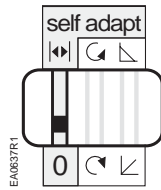

**Figure 14.**  
**Self-adapt**  
**Switch.**

The factory setting is 0 (OFF).

When mechanical angle of rotation is limited, the self-adapt switch may be turned ON  so that the limited range will become the new 0 to 100% for the actuator logic. In this case, 0 to 100% is not equal to 90°



#### CAUTION:

When turning the self-adaptive feature on or after a software reset with the feature on, the actuator will enter a five-minute calibration cycle as the actuator adjusts to the rotation limits of the system. A software reset happens after power on or may be caused by electrostatic discharge (ESD) at levels of 2kV and above.

The position output signal U is not influenced by the self-adapt function. The 0 to 10V feedback signal U is always proportional to 0 to 90° (or 90 to 0°)

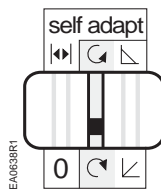

**Figure 15.**  
**Direction of**  
**Rotation Switch.**

The factory setting is clockwise.

The direction of rotation switch should match the damper rotation movement.

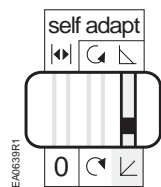

**Figure 16.**  
**Output Signal**  
**Switch.**

The factory setting is direct acting.

As the clockwise angle of rotation increases, the output voltage increases.

If the direction of rotation is counterclockwise, the output signal switch should be set at reverse acting to match the direction of the rotation switch.

**NOTE:** Feedback not available on terminal strip models.

## Sizing

The type of actuator required depends on several factors.

1. Obtain damper torque ratings (ft-lb/ft<sup>2</sup> or Nm/m<sup>2</sup>) from the damper manufacturer.
2. Determine the area of the damper.
3. Calculate the total torque required to move the damper:

$$\text{Total Torque} = \frac{\text{Torque Rating} \times \text{Damper Area}}{\text{SF}^1}$$

<sup>1</sup> Safety Factor: When determining the torque of an actuator required, a safety factor should be included for unaccountable variables such as slight misalignments, aging of the damper, etc. A suggested safety factor is 0.80 (or 80% of the rated torque).

4. Select the actuator type from Table 3.

**Table 3.**

Total Torque	Actuator
<44 lb-in (5 Nm)	GDE16x
<88 lb-in (10 Nm)	GLB16x
<132 lb-in (15 Nm)	GEB16x
<177 lb-in (20 Nm)	GBB16x
<310 lb-in (35 Nm)	GIB16x
>310 lb-in >620 lb-in (35 Nm – 70 Nm)	Master/Slave actuators (See <i>Technical Instructions 155-542P2</i> ) OR Use tandem mounting bracket ASK73.2U with any combination of GIB16x actuators.

## Mounting and Installation

- Place the actuator on the damper shaft so that the front of the actuator is accessible. The label is on the front side. A mounting bracket is included with the actuator.
- The minimum damper drive shaft length is 3/4-inch (20 mm).
- Observe the service envelope around the actuator as shown in Figure 22.
- Detailed mounting instructions are included with each actuator.

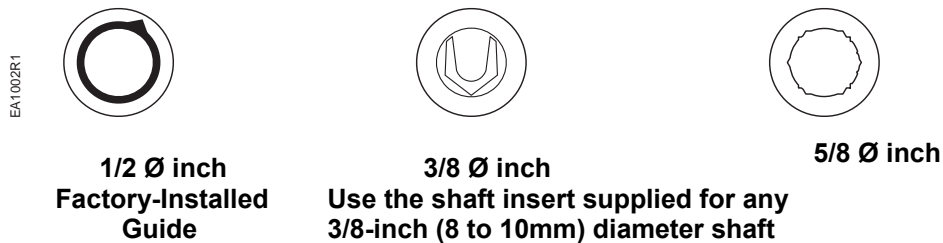

**Figure 17. Damper Shaft Sizes.**

**NOTE:** For all damper shafts with the exception of the 1/2-inch round shaft: Remove 1/2 Ø inch guide before installation.

**Manual override**

To move the damper blades and lock the position with no power present:

1. Slide the red manual override knob toward the back of the actuator.
2. Make adjustments to the damper position.
3. Slide the red manual override knob toward the front of the actuator.

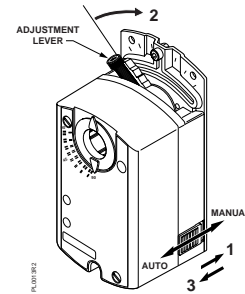

**Figure 18. Manual Override.**

Once power is restored, the actuator returns to automated control.

**Mechanical range adjustment**

To mechanically limit the range of the damper blade.

1. Loosen the stop set screw.
2. Move the screw along the track to the desired position, and fasten it in place.

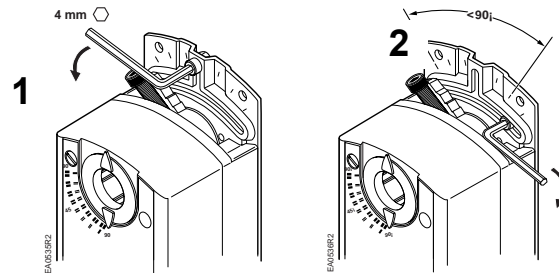

**Figure 19. Moving the Mechanical Range Stop.**

To use the entire 0 to 10V input signal to control the mechanically limited range: See Figure 7 for setting self-adaptive features.

**Example:**

Stop set screw at  $70^\circ$   
 Self-adapt switch ON  
 Input signal Y = 5 Vdc

The damper will be at  $35^\circ$  (50% of the adjusted range.)

**NOTE:** On versions with the slope and offset features, this example assumes  
 Offset  $U_0 = 0$  Vdc  
 Slope  $\Delta U = 10$  Vdc

## Wiring

- All wiring must conform to NEC and local codes and regulations.
- Use earth ground isolating step-down Class 2 transformers. Do not use autotransformers.
- The sum of the VA ratings of all actuators and all other components powered by one transformer must not exceed the rating of the transformer.
- It is recommended that one transformer power no more than ten actuators.



### WARNING:

All six outputs of the dual auxiliary switch (A and B) must only be connected to:  
 Class 2 voltage (UL/CSA).  
 Separated Extra-Low Voltage (SELV) or Protective Extra Low Voltage (PELV)  
 (according to HD384-4-41) for installations requiring **CE** conformance.



### WARNINGS:

Installations requiring **CE** Conformance:

- All wiring for CE certified actuators must be "Separated Extra Low Voltage" (SELV) or "Protective Extra Low Voltage" (PELV) rated per HD384-4-41.
- Use safety-isolating transformers (Class III transformer) per EN61558. They must be rated for 100% duty cycle.
- Overcurrent protection for supply lines is maximum 10A.

## Wiring Designations

Each wire has the standard symbol printed on it.

24 Vac power supply

0 to 10V modulating control

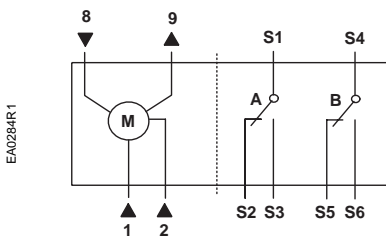

Table 4.

Standard Symbol	Function	Terminal Designation	Color
1	Supply (SP)	G	Red
2	Neutral (SN)	G0	Black
8	0 to 10V input signal	Y	Gray
9	Output for 0 to 10 Vdc position indication	U	Pink

### Factory-installed Options

S1	Switch A Common	Q11	Black
S2	Switch A - N.C.	Q12	Black
S3	Switch A - N.O.	Q14	Black
S4	Switch B - Common	Q21	Black
S5	Switch B - N.C.	Q22	Black
S6	Switch B - N.O.	Q24	Black

## Wiring Designations, Continued

### GDE161.1T

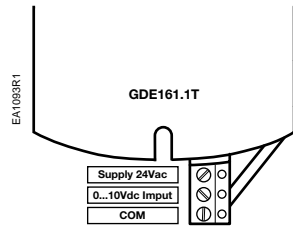

**Figure 20. GDE161.1T Terminal Strip Wiring Connections.**

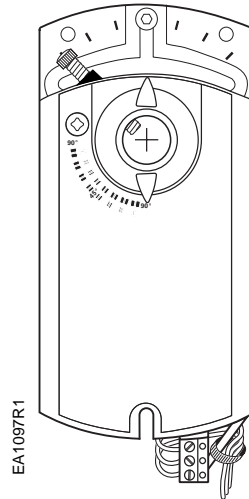

**Figure 21. GDE161.1T Strain Relief.**

#### NOTES:

- The GDE161.1T does not provide a feedback signal.
- Maximum wire size 14 AWG.
- The open bracket to the right of the actuator terminal strip is the strain relief for the customer provided control wires. Secure the wires to the actuator bracket with a tie wrap as shown in Figure 21.

## Start-Up/Commissioning

1. Check that the wires are connected correctly.
2. Check that offset and slope are set correctly, if used.
3. Check that the direction of rotation switch matches the rotation of the damper shaft.
4. Connect wires 1 (red) and 2 (black) to a Digital Multimeter (DMM) with the dial set at AC V to verify that the operating voltage is within range.

#### Check operation:

1. Connect wires 1 (red) and 2 (black) to the actuator.
2. Set the DMM dial to Vdc.
3. Connect wires 2 (black) and 8 (gray) to the DMM.
4. Apply a full-scale input signal (10 Vdc) to wire 8 (gray).
5. Allow the actuator shaft coupling to rotate from 0 to 90°.
6. Disconnect wire 8 (gray) and the shaft coupling returns to the "0" position.

#### Check Feedback:

1. Set the DMM dial to Vdc.
2. Attach wires 2 (black) and 9 (pink) to the DMM.
3. Apply a full-scale input signal to wire 8 (gray). The reading at the DMM should increase.
4. Remove the signal from wire 8 (gray). The reading at the DMM should decrease and the actuator shaft coupling returns to the "0" position.

#### Check the Auxiliary Switch A:

1. Set the DMM dial to Ohms (resistance) or continuity check.
2. Connect wires S1 and S3 to the DMM. The DMM should indicate open circuit or no resistance.
3. Apply a full-scale input signal to wire 8 (gray). The DMM should indicate contact closure as the actuator shaft coupling reaches the setting of switch A.
4. Connect wires S1 and S2 to the DMM. The DMM should indicate open circuit or no resistance.
5. Stop the signal to wire 8 (gray). The DMM should indicate contact closure as the actuator shaft coupling reaches the setting of switch A.

Check the Auxiliary Switch B:

1. Set the DMM dial to Ohms (resistance) or continuity check.
2. Connect wires S4 and S6 to the DMM. The DMM should indicate open circuit or no resistance.
3. Apply a full-scale input signal to wire 8 (gray). The DMM should indicate contact closure as the actuator shaft coupling reaches the setting of switch B.
4. Connect wires S4 and S5 to the DMM. The DMM should indicate open circuit or no resistance.
5. Stop the signal to wire 8 (gray). The DMM should indicate contact closure as the actuator shaft coupling reaches the setting of switch B.

Service



**WARNING:**

Do not open the actuator.  
 If the actuator is inoperative, replace the unit.

Dimensions

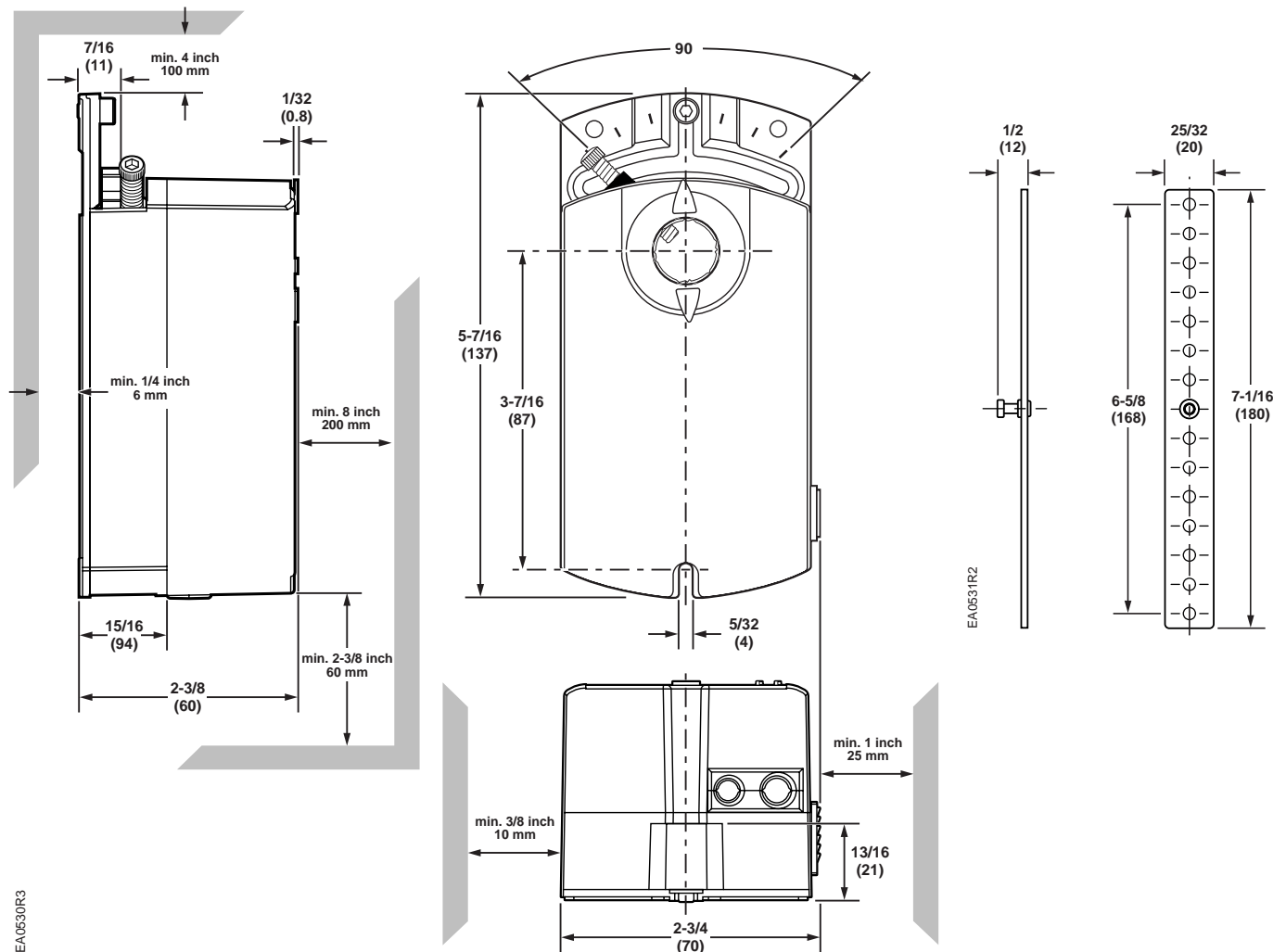
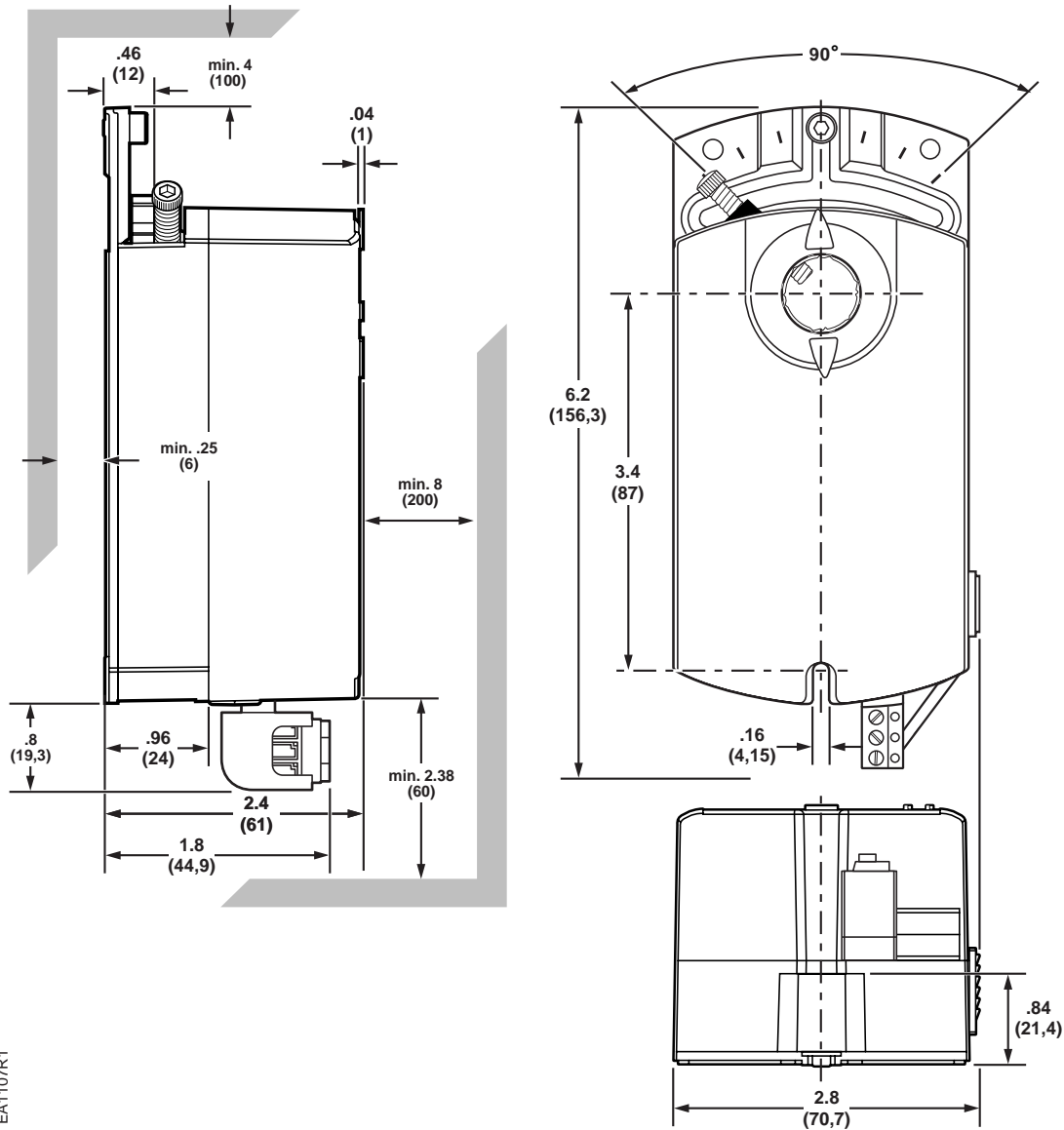

Figure 22. GDE/GLB Actuator and Mounting Bracket Dimensions in Inches (mm).

**Dimensions, continued**



EA1107R1

**Figure 23. GDE161.1T Dimensions in Inches (mm).**

Information in this publication is based on current specifications. The company reserves the right to make changes in specifications and models as design improvements are introduced. OpenAir is a trademark of Siemens Building Technologies, Inc. Other product or company names mentioned herein may be the trademarks of their respective owners. © 2004 Siemens Building Technologies, Inc.