

VSI

Electric Actuators



SERIES 1000

Installation and Operations Manual

Table of Contents

Product Overview

Series 1000 On-Off Rotary Electric Actuator

Series 1000s Modulating Rotary Electric Actuator

Brushless DC Rotary Electric Actuator

| | | |
|----------|--|------------|
| 1 | Safety Notices | 1-1 |
| 2 | Installation | 2-1 |
| | 2.1 Mechanical Installation onto the Valve..... | 2-3 |
| | 2.2 Electrical Connections..... | 2-3 |
| | 2.2.1 Remove the side cover..... | 2-3 |
| | 2.2.2 Connect the cable pipe to the conduit entry..... | 2-4 |
| | 2.2.3 Terminal Connections..... | 2-4 |
| 3 | Adjustment | 3-1 |
| | 3.1 Adjustment of cam angle..... | 3-1 |
| | 3.2 Adjustment of mechanical stop..... | 3-2 |
| 4 | Operation | 4-1 |
| | 4.1 Manual Override Operation..... | 4-1 |
| | 4.2 Electrically Powered Operation..... | 4-2 |
| | 4.2.1 Initial Calibration..... | 4-2 |
| | 4.2.2 Signal Fail Mode Selection..... | 4-2 |
| | 4.2.3 Input Control Signal..... | 4-3 |
| | 4.2.4 Output Feedback Signal..... | 4-3 |
| | 4.2.5 LEDs..... | 4-3 |
| 5 | Troubleshooting | 5-1 |
| 6 | Maintenance | 6-1 |

Figures

| | |
|--|-----|
| Figure 2-1 Dimensions used for installation..... | 2-1 |
| Figure 2-2 Assembly with the valve..... | 2-3 |
| Figure 2-3 Removal of side cover for wiring work..... | 2-3 |
| Figure 2-4 Installation of the cable pipe..... | 2-4 |
| Figure 2-5 Wiring Diagram for On-Off Models..... | 2-4 |
| Figure 2-6 Terminal block connections..... | 2-5 |
| Figure 2-7 Wiring Diagram for Modulating Models..... | 2-6 |
| Figure 2-8 Wiring Diagram for DC Models..... | 2-6 |
| Figure 2-9 Wiring Diagram for BLDC Models..... | 2-7 |
| Figure 3-1 Cam adjustment for Series 1005, 1010, 1010s, 1040, 1040s..... | 3-1 |
| Figure 3-2 Cam adjustment for Series 1200, 1200s..... | 3-1 |
| Figure 3-3 Bottom view of the stop..... | 3-2 |
| Figure 4-1 Manual Override..... | 4-1 |
| Figure 4-2 Signal Fail Mode Setting..... | 4-2 |
| Figure 4-3 Position Indicator and Output Feedback..... | 4-3 |

Tables

| | |
|---|-----|
| Table 1: On-Off Actuator Specifications..... | 0-1 |
| Table 2: Modulating Actuator Specifications..... | 0-2 |
| Table 3: BLDC Actuator Specifications..... | 0-3 |
| Table 4: Dimensions in Inches (Millimeters)..... | 2-2 |
| Table 5: Troubleshooting Problems for Actuator Operation..... | 5-1 |

Series 1000 On-Off Rotary Electric Actuator

Table 1: On-Off Actuator Specifications

| Model | 1005 | 1010 | 1040 | 1200 |
|-----------------------------------|--|-----------|----------|----------|
| Output Torque (in-lb) | 347 | 868 | 3472 | 17,359 |
| Output Torque (Nm) | 39.23 | 98.06 | 392.27 | 1961.32 |
| Duty Cycle | 75% | 75% | 50% | 50% |
| Travel Speed at 60Hz(sec) | 25 | 25 | 25 | 50 |
| Maximum Current (mA @ 110/220Vac) | 0.35/0.18 | 0.41/0.22 | 1.66/0.9 | 2.4/1.21 |
| Enclosure Rating | Watertight, NEMA-4,NEMA-4X | | | |
| Weight(lb) | 5.7 | 8.2 | 16.1 | 24.7 |
| Housing | Corrosion-resistant, powder coated, robust aluminum die cast | | | |
| Electric Motor | 120Vac, single phase, 60Hz totally enclosed, non-ventilated, high starting torque, reversible induction type, Class F insulation | | | |
| Thermal Overload Motor Protection | Auto reset thermal switch embedded in the motor winding – trips when the maximum winding temperature is exceeded | | | |
| Position Limit Switches | 2xSPDT for Open and Close travel limit – easily adjustable, cam operated | | | |
| Position Indicator | Mechanical dome type with visible red/yellow closed/open indicator | | | |
| Conduit Entries | 1 x ½” NPT for power and control wiring | | | |
| Power Gears | Alloy steel spur gears to final stage aluminum bronze worm sector gear | | | |
| Break | An electro-mechanical brake is NOT required. The worm gear drive prevents back driving and hunting | | | |
| Bearings | High quality alloy steel sleeve and ball bearings | | | |
| Manual Override | Handle | | | |
| Ambient Temperature Range | -22°F to 140°F | | | |
| Certification and Approvals | CE, NEMA 4, NEMA 4X, NRTL, CSA file 226201 | | | |
| Internal Heater | Included | | | |
| Optional Features | 220Vac/1/50-60Hz power | | | |
| | 12/24Vdc 1005 through 1020 | | | |
| | 24Vac 1005 through 1020 | | | |
| | Feedback Potentiometer – 1000ohm | | | |
| | Torque Limit Switches for Close direction of travel | | | |
| | DeClutchable Hand wheel Override | | | |

Series 1000s Modulating Rotary Electric Actuator

Table 2: Modulating Actuator Specifications

| Model | 1010s | 1040s | 1200s |
|-----------------------------------|--|---------|---------|
| Output Torque (in-lb) | 868 | 3472 | 17,359 |
| Output Torque (Nm) | 98.06 | 392.27 | 1961.32 |
| Duty Cycle | 75% | 50% | 50% |
| Travel Speed at 60Hz(sec) | 25 | 25 | 50 |
| Insulation Resistance | 100Mohm (500Vdc) | | |
| Power Consumption | 70VA | 200VA | 350VA |
| Maximum Current (mA @ 110/220Vac) | 0.65/0.35 | 1.8/0.9 | 3.2/1.6 |
| Enclosure Rating | Watertight NEMA-4, NEMA-4X | | |
| Weight(lb) | 8.6 | 16.5 | 26.1 |
| Control Module | Direct digital control input 4 – 20mA or 2 – 10 Vdc from controller. The module provides 4 – 20mA output for feedback | | |
| Housing | Corrosion-resistant, powder coated, robust aluminum die cast | | |
| Electric Motor | 120Vac, single phase, 60Hz totally enclosed, non-ventilated, high starting torque, reversible induction type, Class F insulation | | |
| Thermal Overload Motor Protection | Auto reset thermal switch embedded in the motor winding – trips when the maximum winding temperature is exceeded | | |
| Resolution | 80 steps (4-20mA) or 200 steps (2-10Vdc) through 90° travel | | |
| Power at Reset | 2VA | | |
| Position Indicator | Mechanical dome type with visible red/yellow closed/open indicator | | |
| Conduit Entries | 2 x ½” NPT for power and control wiring | | |
| Power Gears | Alloy steel spur gears to final stage aluminum bronze worm sector gear | | |
| Break | An electro-mechanical brake is NOT required. The worm gear drive prevents back driving and hunting | | |
| Bearings | High quality alloy steel sleeve and ball bearings | | |
| Manual Override | Handle | | |
| Ambient Temperature Range | -22°F to 140°F | | |
| Certification and Approvals | CE, NEMA 4, NEMA 4X, NRTL, CSA file 226201 | | |
| Optional Features | 220Vac/1/50-60Hz power | | |
| | 2xSPDT Auxiliary Switches | | |
| | Space Heater | | |
| | Torque Limit Switches for Close direction of travel | | |
| | DeClutchable Hand wheel Override | | |

Brushless DC Rotary Electric Actuator (Switch between On-Off and Modulating mode)

Table 3: BLDC Actuator Specifications

| Model | 2200 | 4400 |
|-----------------------------------|--|-------------------|
| Output Torque (in-lb) | 2200 | 4400 |
| Output Torque (Nm) | 248.5 | 497.2 |
| Duty Cycle | 100% | 100% |
| Travel Speed at 60Hz(sec) | 6 Min/12 Nominal | 12 Min/25 Nominal |
| Power Consumption | 150VA | 150VA |
| Enclosure Rating | Watertight NEMA-4, NEMA-4X | |
| Weight(lb) | 19.84 | 19.84 |
| Control Module | Direct digital control input 4 – 20mA or 2 – 10 Vdc from controller. The module provides 4 – 20mA output for feedback | |
| Housing | Corrosion-resistant, powder coated, robust aluminum die cast | |
| Electric Motor | 120Vac, single phase, 60Hz totally enclosed, non-ventilated, high starting torque, reversible induction type, Class F insulation | |
| Thermal Overload Motor Protection | Auto reset thermal switch embedded in the motor winding – trips when the maximum winding temperature is exceeded | |
| Resolution | Up to 250 steps through 90° travel | |
| Position Indicator | Mechanical dome type with visible red/yellow closed/open indicator | |
| Conduit Entries | 2 x ½” NPT for power and control wiring | |
| Power Gears | Alloy steel spur gears to final stage aluminum bronze worm sector gear | |
| Break | An electro-mechanical brake is NOT required. The worm gear drive prevents back driving and hunting | |
| Bearings | High quality alloy steel sleeve and ball bearings | |
| Manual Override | Handle | |
| Mechanical Stops | Included | |
| Ambient Temperature Range | -22°F to 140°F | |
| Certification and Approvals | CE, NEMA 4, NEMA 4X, NRTL, CSA file 226201 | |
| Optional Features | 220Vac/1/50-60Hz power | |
| | 2xSPDT Auxiliary Switches | |
| | Hand wheel with 4 holes and 2mm thick flange | |
| | Double stake potentiometer | |
| | Power indication module | |
| | Emergency Action Module | |

1 Safety Notices

1.1 General Purpose

This installation and operation manual shows how to install, operate and maintain the Series 1000 electric actuators.



WARNING: Follow the instructions of this manual for installing, operating, and performing maintenance. Failure to follow these steps may cause serious injury, damage equipment, void warranty or operational difficulty.

1.2 User Safety

To reduce the risk of personal injury and damage to the equipment, the user must read this manual in their entirety before doing the installation and operation works. For your safety, please pay more attention to the “WARNING” and “CAUTION” contents in this manual.

1.3 Storage

To ensure the optimum performance of Series 1000 actuator, please follow the following procedures for actuator’s storage. Series 1000 is a weatherproof unit and comes with all compartment covers and conduit connection entry plugs. It is suggested to store the actuator in a dry warehouse, free from vibration and rapid temperature changes. In the case of outdoor storage, it is suggested to be stored in a clean, dry place and covered to prevent damage.

2 Installation

⚠ WARNING: This is not an explosion proof product. Keep it away from flammable or explosive materials.

⚠ WARNING: Don't turn on the power supply when doing electrical connecting works.

⚠ WARNING: Make sure the ambient temperature is in the range of -22°F (-30°C) to 140°F (60°C).

Caution: For fluid over 212°F (100°C) an extended length bracket and coupling should be used.

Caution: Double check the wiring diagram with your actual connections before power the actuator up.

Caution: Cover the actuator if installed in a place where water or materials are splashing.

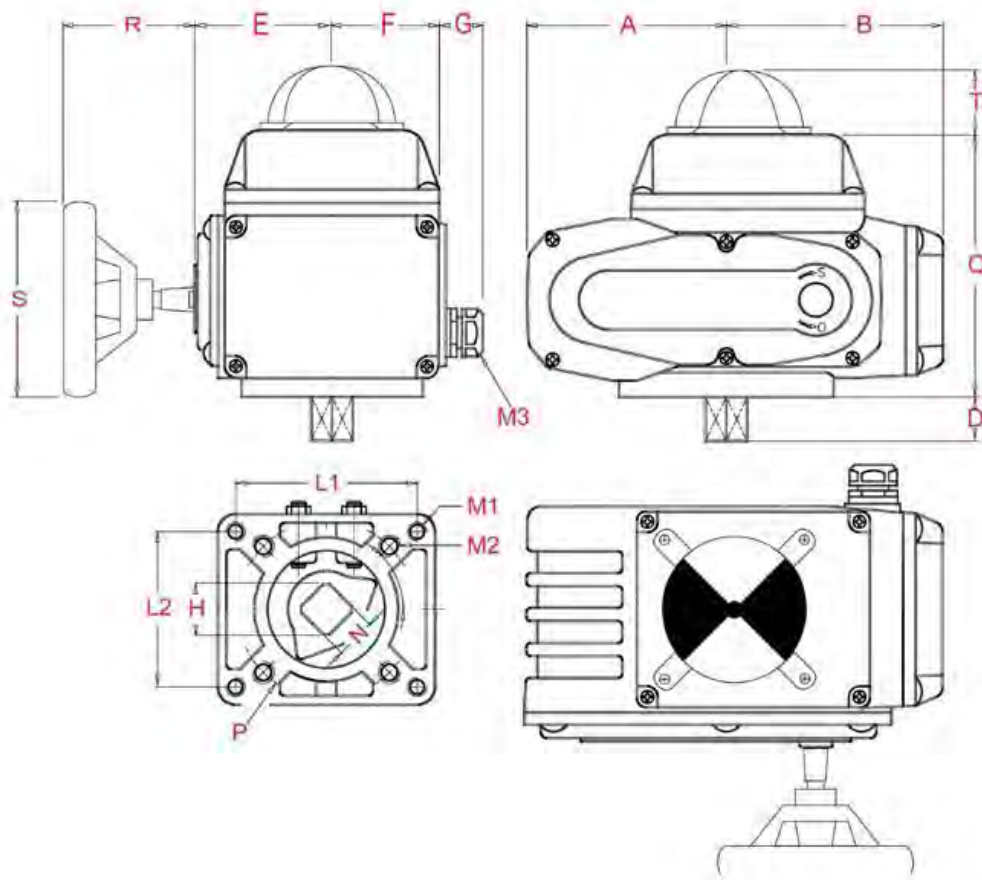

Figure 2-1 Dimensions used for installation

Table 4: Dimensions in Inches (Millimeters)

| Dimension Inches(mm) | 1005 | 1010 1010s | 1040 1040s | 1200 1200s | 2200 4400 |
|-------------------------|----------------|----------------|----------------|----------------|------------------|
| A | 3.386 (86) | 3.858 (98) | 4.843 (123) | 5.039 (128) | 4.843 (123) |
| B | 2.898 (74) | 4.331 (110) | 5.236 (133) | 5.984 (152) | 5.236 (133) |
| C | 4.528 (115) | 4.528 (115) | 5.551 (141) | 6.654 (169) | 5.748 (146) |
| D | 0.55 (14) | 0.63 (16) | 0.866 (22) | 1.024 (26) | N/A |
| E | 2.205 (56) | 2.48 (63) | 3.543 (90) | 3.74 (95) | 3.543 (90) |
| F | 1.772 (45) | 2.047 (52) | 2.48 (63) | 2.402 (61) | 2.480 (63) |
| G | 0.787 (20) | 1.024 (26) | 1.024 (26) | 1.024 (26) | 1.024 (26) |
| L1 | 2.677 (68) | 3.228 (82) | 4.646 (118) | 5.827 (148) | 4.920 (125) |
| L2 | 2.362 (60) | 2.756 (70) | 3.307 (84) | 3.307 (84) | 3.480 (88.4) |
| P | 2.756 (70) | 2.756 (70) | 4.016 (102) | N/A | N/A 4.02X2.84 |
| N | 0.472 (12) | 0.591 (15) | 0.906 (23) | 1.181 (30) | 1.252 (31.8) |
| H | 0.63 (16) | 0.787 (20) | 1.102 (28) | 1.575 (40) | 1.770 (45) |
| M1 | M6X1 | M6X1 | M10X1.25 | M12X1.25 | M12X1.25 |
| M2 | M8X1.25 | M8X1.25 | M10X1.25 | | M10X1.25 |
| M3 | ½ NPT | ½ NPT | ½ NPT | ½ NPT | ½ NPT |
| R | 2.913 (74) | 2.913 (74) | 2.913 (74) | 2.913 (74) | 2.913 (74) |
| S | 4.724 (120) | 4.724 (120) | 4.724 (120) | 4.724 (120) | 4.724 (120) |
| T | 1.102 (28) | 1.102 (28) | 1.102 (28) | 1.102 (28) | 1.102 (28) |

2.1 Mechanical Installation onto the Valve

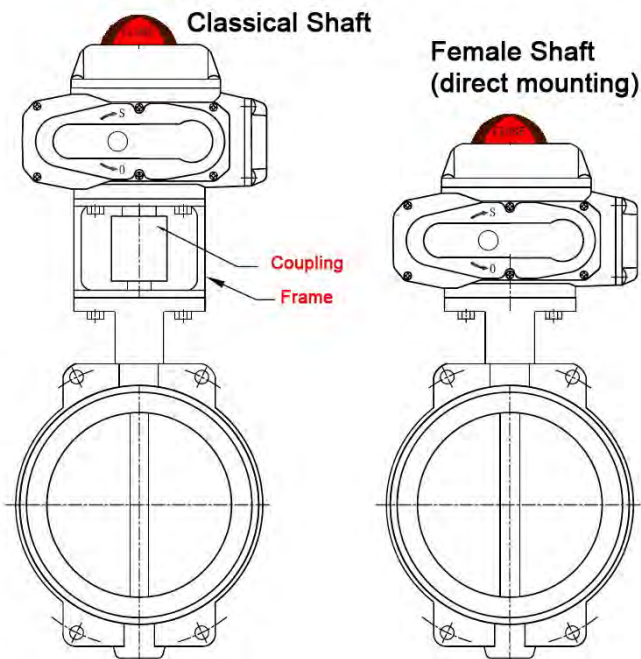

Figure 2-2 Assembly with the valve

1. Verify that the valve is in the closed position.
2. Mount the coupling to the shaft of the valve
3. Mount the bracket to the valve.
4. Mount the actuator to the bracket.
5. Use the manual hand crank on the actuator to confirm that there is no deflection.
6. Wire the actuator up and check the open and close angles.

Notes: Female shaft actuators can be mounted directly to the valve.

Caution: Nuts must be screwed very tight to fix the actuator

2.2 Electrical Connections

2.2.1 Remove the side cover

 **WARNING:** Verify power is off before removing the side cover.

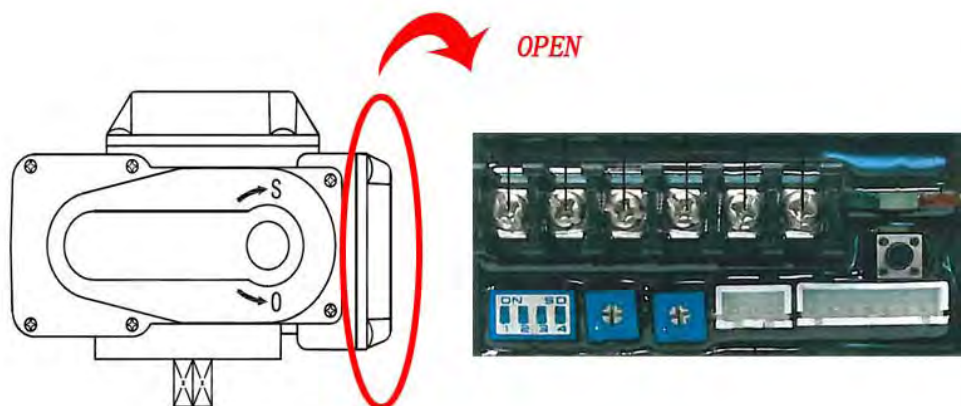

Figure 2-3 Removal of the side cover for wiring work

2.2.2 Connect the cable pipe to the conduit entry

When installed, ensure that the cable/pipe moves to a lower level than the actuator. This helps to prevent water or condensation from entering the actuator.

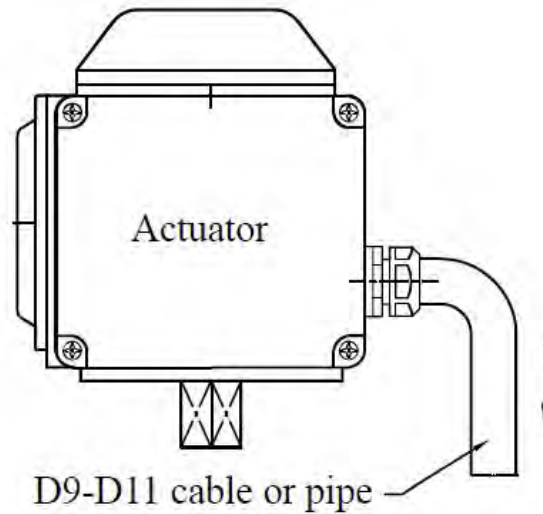

Figure 2-4 Installation of the cable pipe

2.2.3 Terminal Connections

A. On-Off Models: 1005, 1010,1040,1200

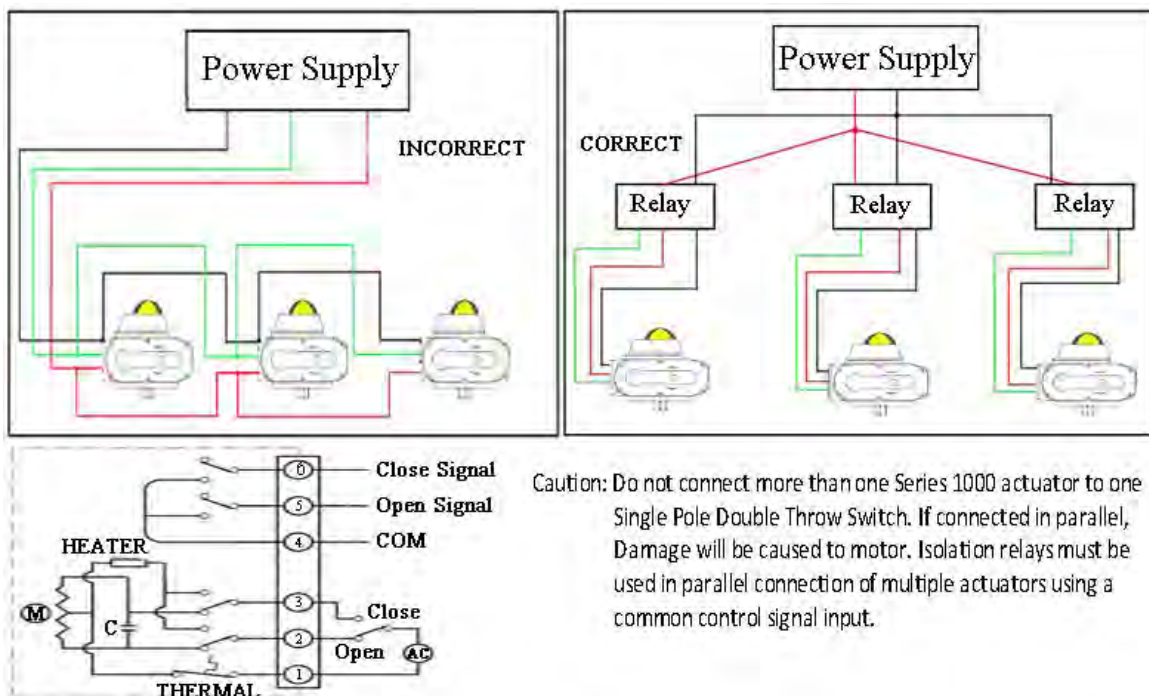

Figure 2-5 Wiring Diagram for On-Off Models

A.1 Power Source

AC 100-120V 50/60Hz

AC 220-240V 50/60Hz

Power supply is connected as showed in Figure 2-7

A.2 Auxiliary Switches

Lead #4, 5 and 6 are used as full open/close feedback. They can be connected to a feedback indication system to show the open/close status of the actuator.

B. Modulating Models: 1010s, 1040s, 1200s

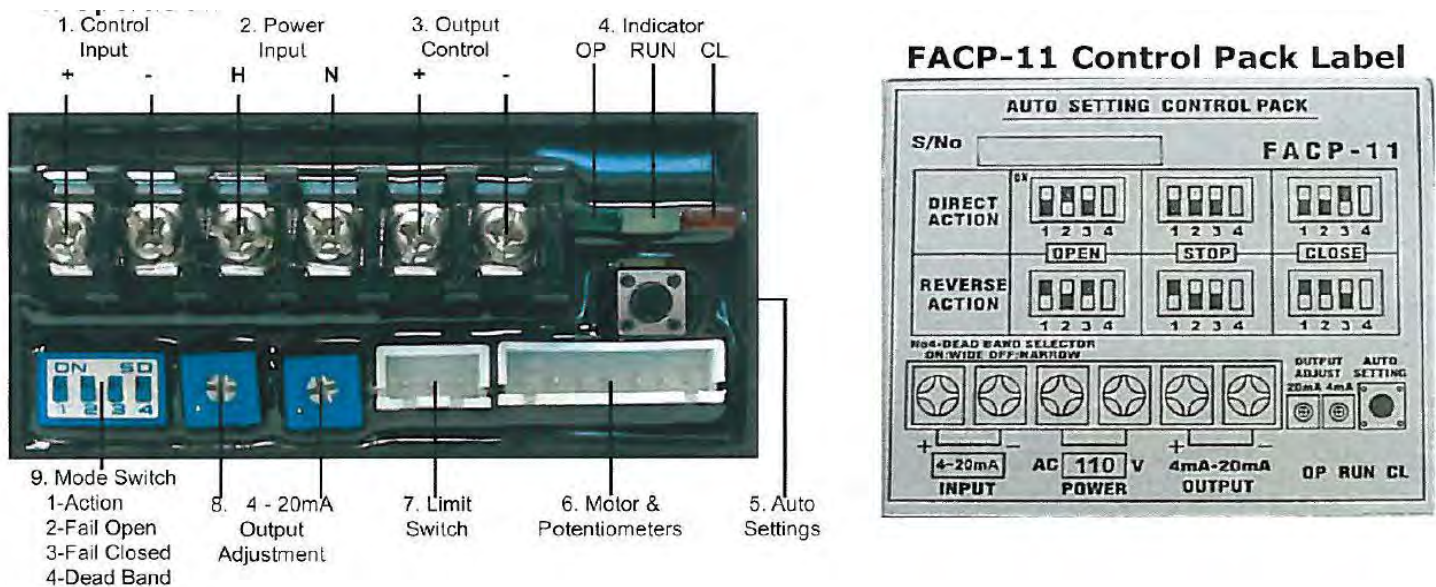

Figure 2-6 Terminal block connections

B.1 Power Source

AC 100-120V 50/60Hz

AC 220-240V 50/60Hz

Connect the main power supply cables, including the ground wire to terminal “H” and “N” (marked on Figure 2-5). The “ground” is connected to the pipe to work as neutral/common. Make sure the connections are hand tightened, including any unused terminal connections.

B.2 Control Signals

The input signal could be 4 to 20mA dc or 2 to 10Vdc. The feedback signal is 4 to 20mA dc. Connect these control inputs and outputs properly will result the inputs current/voltage equal to the outputs.

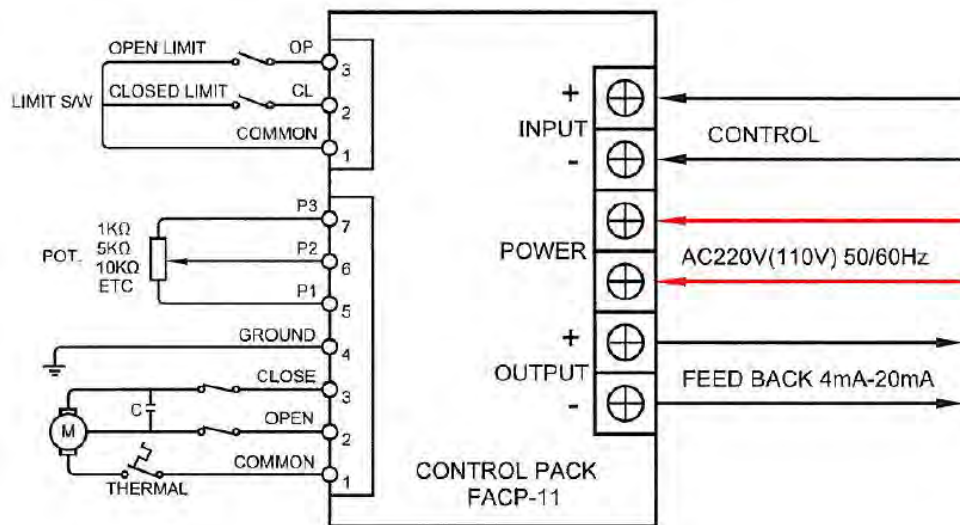

Figure 2-7 Wiring Diagram for Modulating Models

C. Optional models: 12/24 VDC

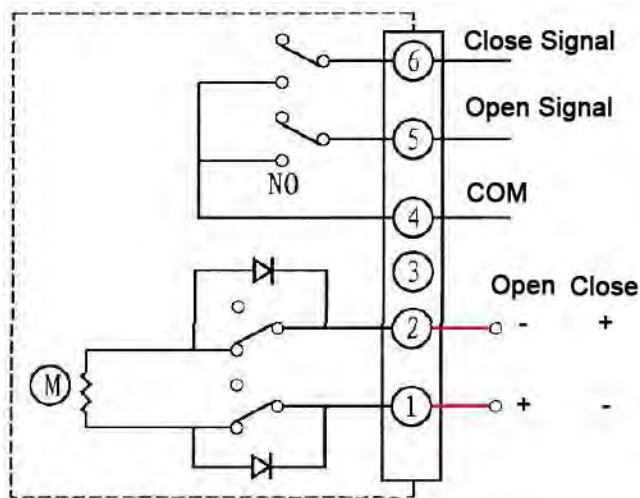

Figure 2-8 Wiring Diagram for DC Models

As you can see in Figure 2-8, open and close is achieved by switching the direction of the power supply. Leads #4, 5 and 6 are used as feedback signals to indicate the status of the actuators.

D. BLDC Models: 2200, 4400

D.1 Power Source

| | |
|-------------|---------|
| AC 100-120V | 50/60Hz |
| AC 220-240V | 50/60Hz |

Connect the power supply as showed in Figure 2-9. Make sure the connections are hand tightened, including any unused terminal connections.

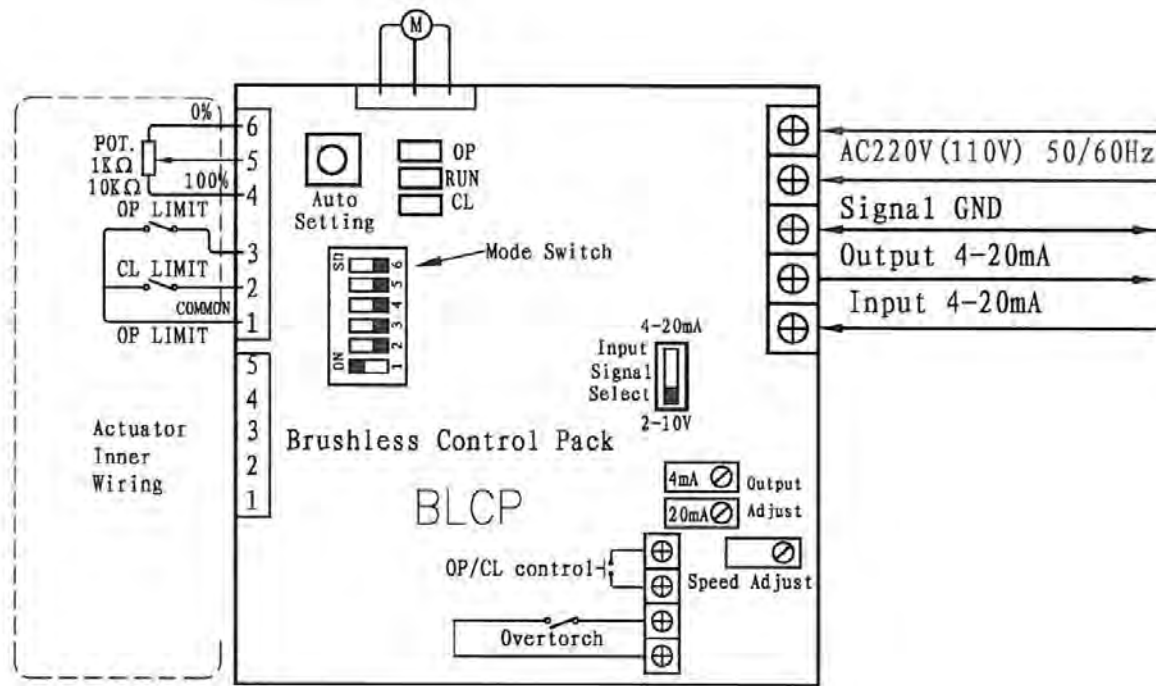

Figure 2-9 Wiring Diagram for BLDC Models

D.2 Control Signals

The input signal could be 4 to 20mA dc or 2 to 10Vdc. The feedback signal is 4 to 20mA dc. Connect these control inputs and outputs properly will result the inputs current/voltage equal to the outputs.

3 Adjustment

3.1 Adjustment of cam angle

The purpose of doing this is to adjust the open or close angle of the actuator. Loose the screw in the cam, knock the cam with a screw driver to change the angle of the cam. Therefore, open/close angle will be changed.

Notes: The change of the angle should be within 5 degree.

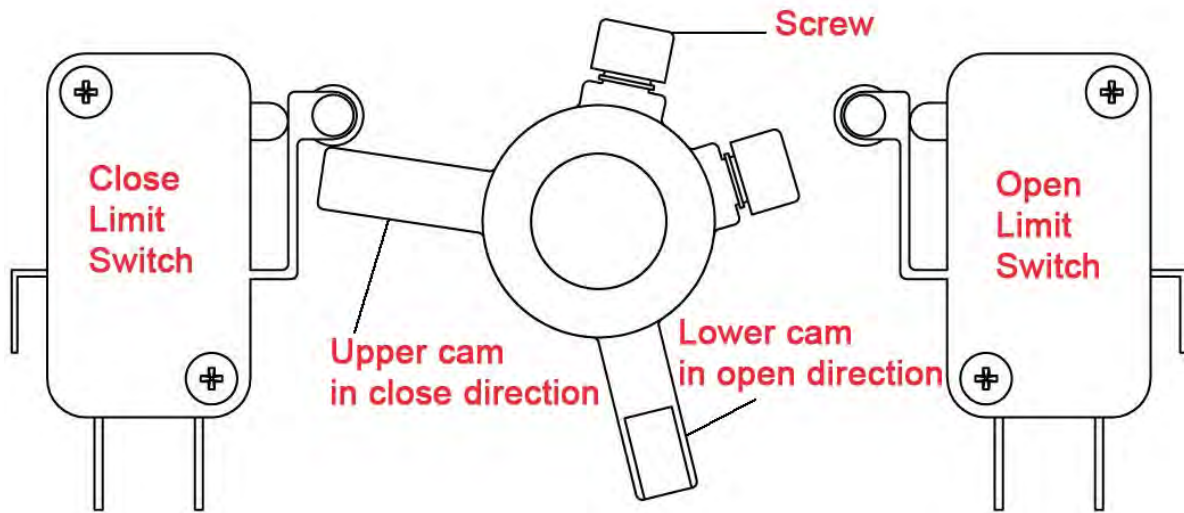

Figure 3-1 Cam adjustment for Series 1005, 1010, 1010s, 1040, 1040s

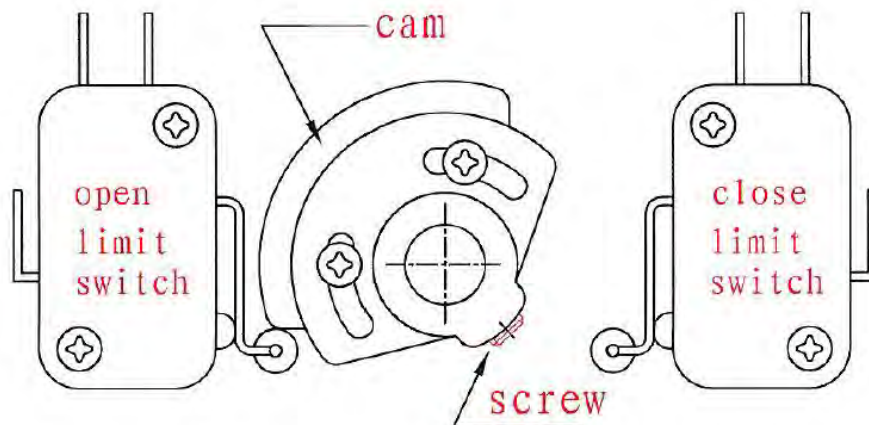
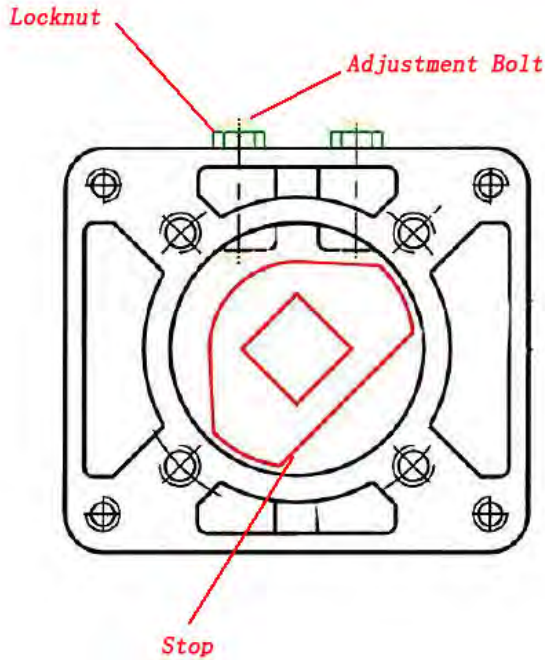

Figure 3-2 Cam adjustment for Series 1200, 1200s

3.2 Adjustment of mechanical stop



1. Manually turn the actuator to fully open position
2. Loose the nut and turn the adjustment bolt to touch the stopper.
3. Turn the bolt by $\frac{1}{2}$ turn in counterclockwise and then tight the locknut up.
4. Repeat the same procedures for close position

Figure 3-3 Bottom view of the stop

⚠ WARNING: Make sure that the cam can activate the limit switch before mechanical stop touches the bolt.

4. Operation

4.1 Manual Override Operation



⚠ WARNING: Turn the power off before making the manual operation. Some of the units have manual override push buttons. Make sure the push button is “OFF” before manual operation (See above figure).

Caution: Don't apply excessive force to the hand wheel when open/close position is reached. Otherwise, the actuator might be damaged.

Steps to manually open and close the actuator:

1. Insert the hand wheel into the hexagonal hole under the rubber cover.
2. Turn clockwise to close and turn counterclockwise to open.
3. Check the open/close indicator to reach specific positions.

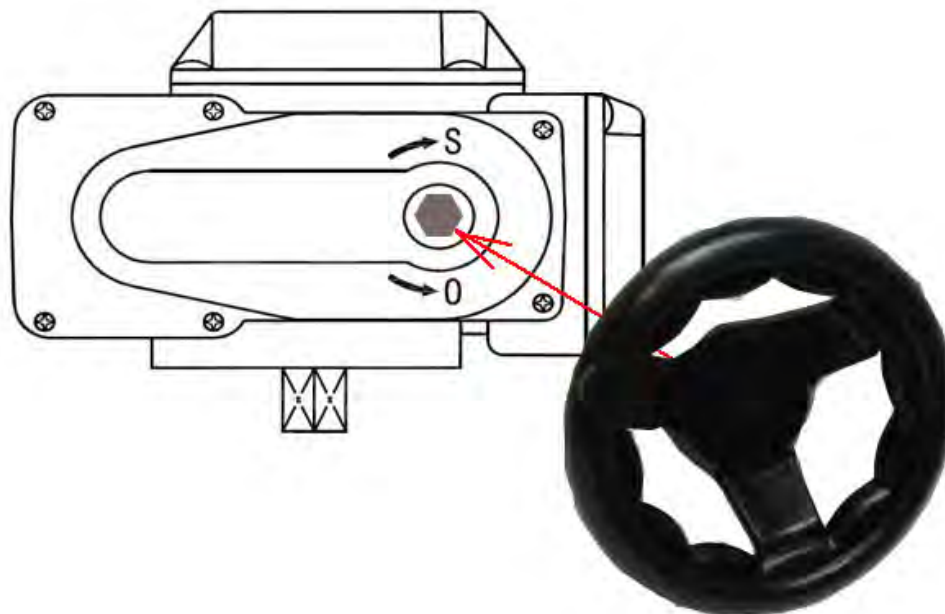

Figure 4-1 Manual Override

4.2 Electrically powered operation

Caution: Before turning the power on, please check the electrical connections as showed in Part 2.2.3.

4.2.1 Initial Calibration

A. On-Off Models

Manually open and close the actuator to find the limit switches. Make sure the cam make good contact with the limit switches when it turns open and close.

B. Modulating Models and BLDC Models

Turn on the power when the connections are OK. The first step is to press the auto setting switch for 3 seconds and then release it. The actuator will cycle open and close twice to find both limit switches and calibrate the actuator.

4.2.2 Signal Fail Mode Selection (Modulating Models and BLDC Models Only)

You can also set the signal fail mode to define what happens when control signal lost. Follow the Figure 4-2 to set “Fail Open”, “Fail Stop” or “Fail Close” mode in either direct action or reverse action.

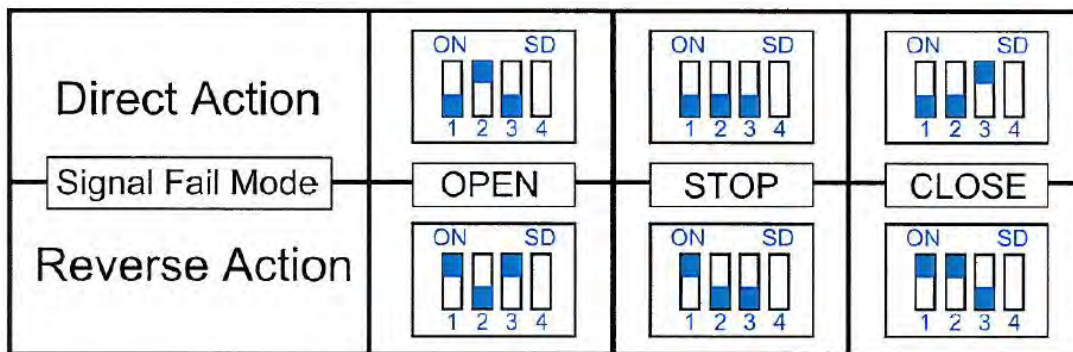

Figure 4-2 Signal Fail Mode Setting

DIP Switch #1 is for Direct/Reverse Action selection

DIP Switch #2 & 3 are for selecting the valve position when loss of control signal occurs.

DIP Switch #4 is for dead band: ON for Wide dead band, and OFF for Narrow dead band.

DIP Switch #5 is for Local Adjustment: ON for Local adjustment, and OFF for receiving Remote Signals. (BLDC Models Only)

DIP Switch #6 is for valve Control (DIP off)/On-Off (DIP on) mode selection; in On-Off mode, an external contact will initiate the On/Off action (Contact close to open the valve & Contact open to close the valve). (BLDC Models Only)

4.2.3 Input Control Signal (Modulating Models and BLDC Models Only)

Caution: Before operating the actuator in the whole control system, please test it by inputting the signal (0%, 25%, 50%, 75%, 100%) to ensure the open degree is correct and connecting an indicator (current meter) to Output Terminal to ensure the output current.

The control input signal could be either 4-20mA or 2-10 Vdc. The rangeability of control is over 200:1 resolution for 2-10Vdc and 80:1 resolution for 4-20mA.

4.2.4 Output Feedback Signal

A. On-Off Models

The output feedback for this on-off model is a user connected close circuit with user's own indicating device in it.

B. Modulating Models and BLDC Models

The output feedback signal is 4-20mA to match with the degree of open or close.

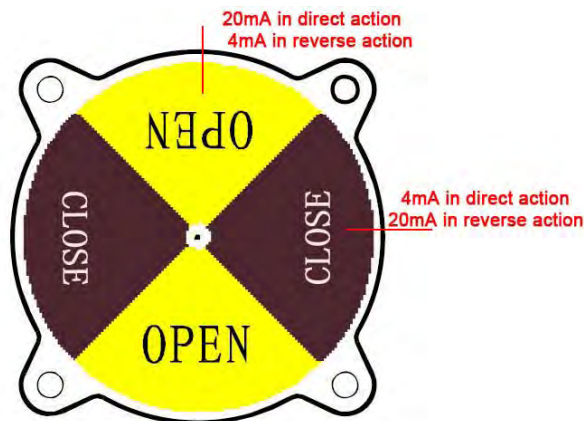

Figure 4-3 Position Indicator and Output Feedback

4.2.5 LEDs

Green on – Actuator is opening

Yellow on – Actuator is operating

Yellow Flashing – Fully open/closed

Yellow Flashing Quickly – System Fail: Power should be turned off right away, check LS, motor for jamming; correct problems before start the normal operation again.

Red on – Actuator is closing

5. Troubleshooting

Table 5: Troubleshooting Problems for Actuator Operation

| Problem | Probable Cause | Corrective Action |
|--|--|---|
| Motor doesn't run | Power off | Turn on the power supply |
| | Open in Circuit | Refer to appropriate wiring diagram and check for continuity |
| | Low or wrong power source | Check for proper voltage |
| | Failure of Limit switch | Adjust the cam position or replace a new limit switch |
| | Stuck in gears | Check movements by manual override |
| Fully open or close position cannot be reached | Limit switch improperly set | Calibrate the position of the limit switch |
| | Cam incorrectly adjusted | Re-adjust the cam |
| Hand wheel will not turn the actuator | Hand wheel shaft bearing assembly malfunction | Repair or replace as necessary |
| | Hand wheel shaft broken | Repair or replace as necessary |
| | Valve packing gland too tight | Loosen packing gland nuts as necessary |
| | Drive sleeve bearing failure | Replace bearing |
| | Jammed valve | Refer to valve maintenance |
| LED doesn't light up | LED broken | Replace a LED |
| | Expected action/function not happened | Check the operation manual for correct operation |
| Input signal is not equal to the output feedback signal | Potentiometer fails | Check the connections of potentiometer or replace the potentiometer |
| Thermal overload frequently cuts out motor | Frequency of Operation exceeds duty cycle rating | Check cycling period |
| There is water and/or moisture inside of the unit | Conduit fitting installed improperly | Re-install correctly |
| | Cover and/or base seal damaged | Replace damaged seal(s) |
| | Base gasket damaged or installed improperly | Check gasket and replace if necessary |
| | Unit has been submerged | Raise unit above liquid level |

6. Maintenance

 **WARNING:** To reduce the chance of electrical shock, disconnect power before any maintenance or repairs are performed.

Series 1000 actuators are virtually maintenance free for a long period of operation. However, it is strongly recommended to make periodic checks to ensure that all fasteners are tight and properly torque to extend the life of the actuator and valve.

After a long period of rest, it's better to operate the actuator manually first to ensure smooth movement of the valve without eccentricity. If possible, please recheck the wiring and see if there are some connection problems.